

AT9000 Advanced Transmitter

Gauge Pressure Transmitters

OVERVIEW

AT9000 Advanced Transmitter is a microprocessor-based smart transmitter that features high performance and excellent stability. Capable of measuring gas, liquid, vapor, and liquid levels, it transmits 4 to 20 mA DC analog and digital signals according to the measured pressure. It can also execute two-way communications between the CommPad (Handy Communicator) or HART® 375 communicator, thus facilitating self-diagnosis, range resetting, and automatic zero adjustment.



FEATURES

High performance and stability

- Unique characterization and composite semiconductor sensors realize high accuracy up to 0.04% F.S.
- Our proven sensor technology enables Long-term stability up to 0.1% of URL per 10-year.

Wide measuring range (range ability)

- A wide measuring range is available from a single model. This feature is highly effective in taking measurement over a wide range and reducing the need for inventory.
- Model GTX60G: 2.54 to 508 psi (17.5 to 3500 kPa) (range ability: 200 to 1)

A diverse lineup

- A wide range of models is available to meet user requirements for low, standard, and high pressures.
- A wide variety of corrosion-resistant materials for wetted parts is also available.

Remote communication

- Two-way communication using digital output facilitates self-diagnosis, range resetting, automatic zero adjustment, and other operations.
- HART® protocol communication is available. (Option)

China RoHS

This device is used in the Oil & Gas, Petrochemical, Chemical, Pulp & Paper, Food & Beverage, Machinery, Steel/Metal & Mining, and Automobile industries and therefore does not fall under the China RoHS Legislation.

If this device is used in semiconductor manufacturing equipment, labeling on the device and documents for the China RoHS may be required. If such documents are required, consult a Yamatake representative.

HART® is a registered trademark of the HART Communication Foundation.

FUNCTIONAL SPECIFICATIONS

Type of protection

NEMA3 and 4X
IEC IP67

FM Explosionproof and Dust Approvals

Explosionproof for Class I, Division 1, Groups A, B, C and D; Class I, Zone 1, AEx d IIC
Dust-Ignitionproof for Class II, III, Division 1, Groups E, F and G
T5 $-40^{\circ}\text{C} \leq T_{\text{amb}} \leq +85^{\circ}\text{C}$
Hazardous locations
Indoor / Outdoor Type 4X, IP67
Factory sealed, conduit seal not required for Division applications
Caution - Use supply wires suitable for 5°C above surrounding ambient



FM Intrinsically safe Approval

IS/I,II,III/1/ABCDEFGH/T4; $-40^{\circ}\text{C} \leq T_{\text{amb}} \leq +60^{\circ}\text{C}$;
80395278, 80395279, 80395280; Entity; TYPE 4X; IP67
I/O/ AEx ia/IIC/T4; $-40^{\circ}\text{C} \leq T_{\text{amb}} \leq +60^{\circ}\text{C}$; 80395278,
80395279, 80395280; Entity; TYPE 4X; IP67
Entity Parameters: $V_{\text{max}}(U_i)=30$ Volts, $I_{\text{max}}(I_i)=100$ mA,
 $P_i=1$ W, $C_i=10$ nF, $L_i=0.5$ mH

FM Nonincendive Approval

NI/I/2/ABCD/T4; $-40^{\circ}\text{C} \leq T_{\text{amb}} \leq +60^{\circ}\text{C}$; 80395494;
NIFW; TYPE 4X; IP67
NI/I/2/IIC/T4; $-40^{\circ}\text{C} \leq T_{\text{amb}} \leq +60^{\circ}\text{C}$; 80395494;
NIFW; TYPE 4X; IP67
S/II,III/1/EFG/T4; $-40^{\circ}\text{C} \leq T_{\text{amb}} \leq +60^{\circ}\text{C}$;
80395494; NIFW; TYPE 4X; P67
Nonincendive Field Wiring Parameters: $V_{\text{max}}(U_i)=30$
Volts, $C_i=10$ nF, $L_i=0.5$ mH

ATEX Flameproof and Dust Certifications

 0344  KEMA 08ATEX0004

II 1/2 G Ex d IIC T6 $T_{\text{process}}=85^{\circ}\text{C}$
 $-30^{\circ}\text{C} \leq T_{\text{amb}} \leq +75^{\circ}\text{C}$ IP66/67
II 1/2 G Ex d IIC T5 $T_{\text{process}}=100^{\circ}\text{C}$
 $-30^{\circ}\text{C} \leq T_{\text{amb}} \leq +80^{\circ}\text{C}$ IP66/67
II 1/2 G Ex d IIC T4 $T_{\text{process}}=110^{\circ}\text{C}$
 $-30^{\circ}\text{C} \leq T_{\text{amb}} \leq +80^{\circ}\text{C}$ IP66/67
II 2 D Ex tD A21 IP66/67 T85 $T_{\text{process}}=85^{\circ}\text{C}$
 $-30^{\circ}\text{C} \leq T_{\text{amb}} \leq +75^{\circ}\text{C}$
II 2 D Ex tD A21 IP66/67 T100 $T_{\text{process}}=100^{\circ}\text{C}$
 $-30^{\circ}\text{C} \leq T_{\text{amb}} \leq +75^{\circ}\text{C}$
II 2 D Ex tD A21 IP66/67 T110 $T_{\text{process}}=110^{\circ}\text{C}$
 $-30^{\circ}\text{C} \leq T_{\text{amb}} \leq +75^{\circ}\text{C}$

Caution - Use supply wires suitable for 5°C above surrounding ambient

ATEX Intrinsic safety and Dust Certifications

 0344  KEMA 07ATEX0200 X

II 1 G Ex ia IIC T4 TPROCESS = 105°C
 $-30^{\circ}\text{C} \leq T_{\text{amb}} \leq +60^{\circ}\text{C}$ IP66 / 67
ELECTRICAL PARAMETERS: $U_i = 30$ V, $I_i = 93$ mA,
 $P_i = 1$ W, $C_i = 5$ nF, $L_i = 0.5$ mH
II 1 D Ex iaD 20 IP66 / 67 T105 TPROCESS = 105°C
 $-30^{\circ}\text{C} \leq T_{\text{amb}} \leq +60^{\circ}\text{C}$

ATEX Type n and Dust Certifications

  KEMA 07ATEX0200 X

II 3 G Ex nL IIC T4 TPROCESS = 105°C
 $-30^{\circ}\text{C} \leq T_{\text{amb}} \leq +60^{\circ}\text{C}$ IP66 / 67
ELECTRICAL PARAMETERS: $U_i = 30$ V, $C_i = 5$ nF, $L_i = 0.5$ mH
II 2 D Ex tD A21 IP66 / 67 T85 TPROCESS = 85°C
 $-30^{\circ}\text{C} \leq T_{\text{amb}} \leq +75^{\circ}\text{C}$
II 2 D Ex tD A21 IP66 / 67 T100 TPROCESS = 100°C
 $-30^{\circ}\text{C} \leq T_{\text{amb}} \leq +80^{\circ}\text{C}$
II 2 D Ex tD A21 IP66 / 67 T110 TPROCESS = 110°C
 $-30^{\circ}\text{C} \leq T_{\text{amb}} \leq +80^{\circ}\text{C}$

NEPSI Flameproof and Dust Certifications

Ex d IIC T6 DIP A21 T_A 85°C $T_{\text{process}}=80^{\circ}\text{C}$ $-40^{\circ}\text{C} \leq T_{\text{amb}} \leq +75^{\circ}\text{C}$
Ex d IIC T5 DIP A21 T_A 100°C $T_{\text{process}}=95^{\circ}\text{C}$ $-40^{\circ}\text{C} \leq T_{\text{amb}} \leq +80^{\circ}\text{C}$
Ex d IIC T4 DIP A21 T_A 115°C $T_{\text{process}}=110^{\circ}\text{C}$ $-40^{\circ}\text{C} \leq T_{\text{amb}} \leq +80^{\circ}\text{C}$
ENCLOSURE TYPE IP66/67
Certificate No. GYJ071268

NEPSI Intrinsic Safety Certification

Ex ia IIC T4 $T_{\text{process}}=105^{\circ}\text{C}$ $-40^{\circ}\text{C} \leq T_{\text{amb}} \leq +60^{\circ}\text{C}$
Enclosure IP66 / 67
Electrical Parameters: $U_i=30$ V, $I_i=100$ mA, $P_i=1$ W,
 $C_i=13$ nF, $L_i=0.5$ mH
Certificate No. GYJ071269

NEPSI Type n Certification

Ex nL IIC T4 $T_{\text{process}}=110^{\circ}\text{C}$ $-40^{\circ}\text{C} \leq T_{\text{amb}} \leq +60^{\circ}\text{C}$
Enclosure IP66 / 67
Electrical Parameters: $U_i=30$ V, $I_i=100$ mA, $P_i=1$ W,
 $C_i=13$ nF, $L_i=0.5$ mH
Certificate No. GYJ071269

IECEx Flameproof and Dust Certifications

Certificate No. IECEx KEM 08.0001
Ga/Gb Ex d IIC T6 $T_{\text{process}}=85^{\circ}\text{C}$ $-30^{\circ}\text{C} \leq T_{\text{amb}} \leq +75^{\circ}\text{C}$ IP66/67
Ga/Gb Ex d IIC T5 $T_{\text{process}}=100^{\circ}\text{C}$ $-30^{\circ}\text{C} \leq T_{\text{amb}} \leq +80^{\circ}\text{C}$ IP66/67
Ga/Gb Ex d IIC T4 $T_{\text{process}}=110^{\circ}\text{C}$ $-30^{\circ}\text{C} \leq T_{\text{amb}} \leq +80^{\circ}\text{C}$ IP66/67
Ex tD A21 IP66/67 T85 $T_{\text{process}}=85^{\circ}\text{C}$ $-30^{\circ}\text{C} \leq T_{\text{amb}} \leq +75^{\circ}\text{C}$
Ex tD A21 IP66/67 T100 $T_{\text{process}}=100^{\circ}\text{C}$ $-30^{\circ}\text{C} \leq T_{\text{amb}} \leq +75^{\circ}\text{C}$
Ex tD A21 IP66/67 T110 $T_{\text{process}}=110^{\circ}\text{C}$ $-30^{\circ}\text{C} \leq T_{\text{amb}} \leq +75^{\circ}\text{C}$
Caution - Use supply wires suitable for 5°C above surrounding ambient

IECEx Intrinsic safety and Dust Certifications

IECEx KEM 07.0058X
Zone 0 Ex ia IIC T4 TPROCESS = 105°C
 $-30^{\circ}\text{C} \leq T_{\text{amb}} \leq +60^{\circ}\text{C}$ IP66 / 67
ELECTRICAL PARAMETERS: $U_i = 30$ V, $I_i = 93$ mA,
 $P_i = 1$ W, $C_i = 5$ nF, $L_i = 0.5$ mH
Ex iaD 20 IP66 / 67 T105 TPROCESS = 105°C
 $-30^{\circ}\text{C} \leq T_{\text{amb}} \leq +60^{\circ}\text{C}$

IECEX Type n and Dust Certifications

IECEX KEM 07.0058X

Ex nL IIC T4 TPROCESS = 105 °C

-30 °C ≤ Tamb ≤ +60 °C IP66 / 67

ELECTRICAL PARAMETERS: Ui = 30 V, Ci = 5 nF, Li = 0.5 mH

Ex tD A21 IP66 / 67 T85 TPROCESS = 85 °C

-30 °C ≤ Tamb ≤ +75 °C

Ex tD A21 IP66 / 67 T100 TPROCESS = 100 °C

-30 °C ≤ Tamb ≤ +80 °C

Ex tD A21 IP66 / 67 T110 TPROCESS = 110 °C

-30 °C ≤ Tamb ≤ +80 °C

EMC Conformity

89/336/EEC, 92/31/EEC, 93/68/EEC Electromagnetic Compatibility (EMC) Directive

Measuring span / Setting range / Working pressure range

Model	Measuring Span	Measuring range	Overload Resistance value
GTX 60G	2.54 to 508 psi (17.5 to 3500 kPa)	-14.5 to 508 psi (-100 to 3500 kPa) (Note 1)	761 psi (5250 kPa)
GTX 71G	101 to 2030 psi (0.7 to 14 MPa)	-14.5 to 2030 psi (-0.1 to 14 MPa) (Note 2)	3045 psi (21 MPa)
GTX 82G	101 to 6091 psi (0.7 to 42 MPa)	-14.5 to 6091 psi (-0.1 to 42 MPa) (Note 3)	9137 psi (63 MPa)

- Note) 1) With PVC parts, the maximum working pressure is 217 psi (1.5 MPa).
 2) With 304 SST bolts and nuts, the maximum working pressure is 1450 psi (10MPa).
 3) With 304 SST bolts and nuts, the maximum working pressure is 3335 (23 MPa).

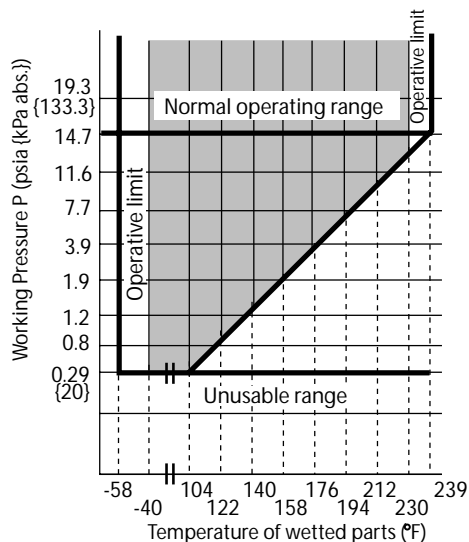

Figure 1 Working pressure and temperature of wetted parts section (for general purpose models)

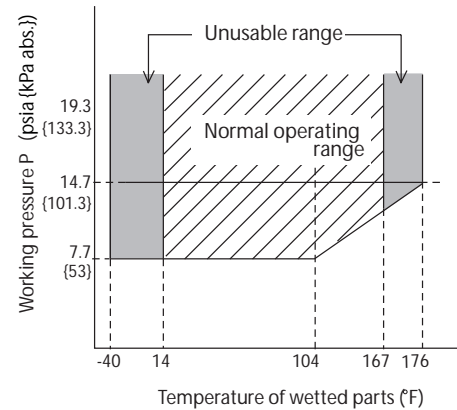

Figure 2 Working pressure and temperature of wetted parts section (for oxygen and chlorine service)

Supply voltage and load resistance

17.9 to 42V DC. A load resistance of 250 Ω or more is necessary between loops. See Figure 3.

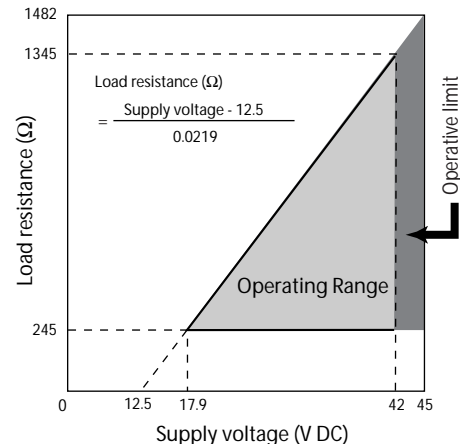

Figure 3 Supply voltage vs. load resistance characteristics

Note) For communication with HART communicator or Comm-Pad, a load resistance of 250 Ω or more is necessary.

Output

Analog output (4 to 20 mA DC) with DE protocol

Analog output (4 to 20 mA DC) with HART protocol

Output signal

3.6 to 21.6 mA

3.8 to 20.5 mA (NAMUR NE43 compliant)

Failure Alarm

Upper: 21.6 mA or more

Lower: 3.6 mA or less

Ambient temperature limit

Normal operating range

-40 to 185°F (-40 to 85°C) for general purpose models

14 to 167°F (-10 to 75°C) for oxygen and chlorine models

-13 to 176°F (-25 to 80°C) for models with digital indicators

Operative limits

-58 to 199°F (-50 to 93°C) for general purpose models

-40 to 176°F (-40 to 80°C) for oxygen and chlorine models

-22 to 185°F (-30 to 85°C) for models with digital indicators

Transportation and storage conditions

-58 to 185°F (-50 to 85°C)

Temperature ranges of wetted parts

Normal operating range

-40 to 230°F (-40 to 110°C) for general purpose models
-4 to 167°F (-20 to 75°C) for oxygen and chlorine models

Operative limits

-58 to 239°F (-50 to 115°C) for general purpose models
14 to 176°F (-10 to 80°C) for oxygen and chlorine models

Ambient humidity limits

5 to 100% RH

Stability against supply voltage change

± 0.005% FS/V

Response time

Below 100 msec. (model GTX60G, when damping time is set to 0 sec.)

Damping time

Selectable from 0 to 32 sec. in ten stages

Zero Stability

± 0.1% of URL per 10 year (model GTX60G)

Lightning protection

Applicable Standards; IEC 61000-4-5

Peak value of current surge(80/20μ sec.): 6000A

Indicator

The digital LCD indicator (optional) indicates engineering units and can be set freely between -99999 and 99999 (5 digits). For meter calibration, specify the following items when placing your order

- Meter calibration range
- Meter calibration unit
- Linear / Square-root for meter indication.

Various kinds of data can be set using the CommPad or the HART[®]375 communicator.

Bolts and nuts materials (for fastening meter body cover)

Carbon steel (SNB7), 304 SST, 630 SST

Paint

Standard

Corrosion-resistant paint (Baked acrylic paint)

Corrosion-proof finish

Corrosion-proof paint (Baked epoxy paint), fungus-proof finish

Corrosion-resistant finish (silver paint)

Transmitter case is coated with silver paint in addition to the above corrosion-resistant finish.

OPTIONAL SPECIFICATIONS

Oil free finish

The transmitter is shipped with oil-free wetted parts.

External zero/span adjustment function

The transmitter can be easily zero/span adjusted in the field.

Elbow

This is an adaptor for changing the electrical conduit connection port from the horizontal to the vertical direction, if required by wiring conditions in the field. One or two elbows may be used as needed.

Conformance to Non SI units

We deliver transmitters set to any Non SI units as specified.

Safety Transmitter

Select this option to be used as a component of Safety Instrumented System (SIS).

AT9000 is complied with IEC61508, certified according to Safety Integrity Level2 (SIL-2)

Alarm Output (contact output)

Contact output is prepared as alarm output when alarm (Output Alarm/Sensor Temp. Alarm) condition is detected. It can be set to Normally Open. (When alarm is detected, Contact ON).

Custom calibration

Calibrate for the specified pressure range at the factory.

PHYSICAL SPECIFICATIONS

Materials

Fill fluid

Silicone oil for general purpose models

Fluorine oil for oxygen and chlorine models

Center body

316 SST

Transmitter case

Aluminum alloy

Meter body cover

SCS14A (Equivalent to 316 SST) or PVC

For Wetted parts

Adapter flange (option)

SCS14A (Equivalent to 316 SST), PVC

Center body

316 SST (Diaphragm 316L SST)

ASTM B575 (Equivalent to Hastelloy C-276), Tantalum, 316L SST

Vents and plugs

316 SST, PVC

Weight

Approx. 3.6 kg (model GTX60G)

INSTALLATION

Electrical connection

1/2NPT internal thread, M20 internal thread.

Grounding

Resistance 100 Ω max.

Mounting

Can be installed on a 2-inch horizontal or vertical pipe (can be directly mounted on a process pipe)

Process connection

Rc1/2, 1/2NPT internal thread and Rc1/4, 1/4NPT internal thread.

WARNING

- Impact to transmitter can damage sensor module.

PERFORMANCE SPECIFICATIONS

Reference accuracy

Shown for each item are the percentage ratio for χ (psi), which is the greatest value of either the upper range value (URV)^{*1}, the lower range value (LRV)^{*2} or the span.

Model GTX60G (for regular service)

(Material of wetted parts: Diaphragm; 316L SST, Others; 316 SST)

Reference accuracy (*3)(*4)		$\pm 0.04\%$	(For $\chi \geq 50.8$ psi (350 kPa))
		$\pm\left(0.008 + 0.032 \times \frac{50.8}{\chi}\right) \%$	(For $\chi < 50.8$ psi (350 kPa))
Ambient Temperature effect (Shift from the set range) Change of 86°F (30°C) (*3)	Combined shift: (including zero and span shifts)	$\pm 0.15\%$	(For $\chi \geq 50.8$ psi (350 kPa))
		$\pm\left(0.075 + 0.075 \times \frac{50.8}{\chi}\right) \%$	(For $\chi < 50.8$ psi (350 kPa))

Model GTX60G (for oxygen / chlorine service)

(Material of wetted parts: Diaphragm; 316L SST, Others; 316 SST)

Reference accuracy (*3)(*4)		$\pm 0.075\%$	(For $\chi \geq 1750$ kPa {17.5 kgf/cm ² })
		$\pm 0.1\%$	(1750 kPa {17.5 kgf/cm ² } > $\chi \geq 140$ kPa {1.4 kgf/cm ² })
		$\pm\left(0.025 + 0.075 \times \frac{140}{\chi}\right) \%$	(For $\chi < 140$ kPa {1.4 kgf/cm ² })
Temperature characteristics (Shift from the set range) Change of 30°C (*3) (Range from -5 to 55°C)	Combined shift: (including zero and span shifts)	$\pm 0.44\%$	(For $\chi \geq 350$ kPa {3.5 kgf/cm ² })
		$\pm\left(0.19 + 0.25 \times \frac{350}{\chi}\right) \%$	(For $\chi < 350$ kPa {3.5 kgf/cm ² })

Model GTX71G

(Material of wetted parts: Diaphragm; 316L SST, Others; 316 SST)

Reference accuracy (*3)(*4)		$\pm 0.15\%$	(For $\chi \geq 304$ psi (2.1 MPa))
		$\pm\left(0.05 + 0.1 \times \frac{304}{\chi}\right) \%$	(For $\chi < 304$ psi (2.1 MPa))
Ambient Temperature effect (Shift from the set range) Change of 86°F (30°C) (*3)	Combined shift: (including zero and span shifts)	$\pm 0.41\%$	(For $\chi \geq 508$ psi (3.5 MPa))
		$\pm\left(0.18 + 0.23 \times \frac{508}{\chi}\right) \%$	(For $\chi < 508$ psi (3.5 MPa))

Model GTX82G

(Material of wetted parts: Diaphragm; 316L SST, Others; 316 SST)

Reference accuracy (*3)(*4)		$\pm 0.15\%$	(For $\chi \geq 1015$ psi (7 MPa))
		$\pm\left(0.05 + 0.1 \times \frac{1015}{\chi}\right) \%$	(For $\chi < 1015$ psi (7 MPa))
Ambient Temperature effect (Shift from the set range) Change of 86°F (30°C) (*3)	Combined shift: (including zero and span shifts)	$\pm 0.41\%$	(For $\chi \geq 1015$ psi (7 MPa))
		$\pm\left(0.18 + 0.23 \times \frac{1015}{\chi}\right) \%$	(For $\chi < 1015$ psi (7 MPa))

Note) *1) URV denotes the process value for 100% (20 mA DC) output.

*2) LRV denotes the process value for 0% (4 mA DC) output.

*3) Within a range of URV ≥ 0 and LRV ≥ 0 .

*4) Reference accuracy at calibrated condition.

Model GTX60G

(Material of wetted parts: Diaphragm; ASTM B575 (Equivalent to Hastelloy C-276), Tantalum, 316L SST Others; ASTM B575 (Equivalent to Hastelloy C-276), Tantalum, 316L SST)

Reference accuracy (*3)(*4)		$\pm 0.2\%$	(For $\chi \geq 50.8$ psi (350 kPa))
		$\pm \left(0.05 + 0.15 \times \frac{50.8}{\chi}\right) \%$	(For $\chi < 50.8$ psi (350 kPa))
Ambient Temperature effect (Shift from the set range) Change of 86°F (30°C) (*3) (Range from 23 to 131°F {-5 to 55°C})	Combined shift: (including zero and span shifts)	$\pm 0.85\%$	(For $\chi \geq 50.8$ psi (350 kPa))
		$\pm \left(0.35 + 0.5 \times \frac{50.8}{\chi}\right) \%$	(For $\chi < 50.8$ psi (350 kPa))

Model GTX71G

(Material of wetted parts: Diaphragm; ASTM B575 (Equivalent to Hastelloy C-276), Tantalum, 316L SST Others; ASTM B575 (Equivalent to Hastelloy C-276), Tantalum, 316L SST)

Reference accuracy (*3)(*4)		$\pm 0.2\%$	(For $\chi \geq 304$ psi (2.1 MPa))
		$\pm \left(0.05 + 0.15 \times \frac{304}{\chi}\right) \%$	(For $\chi < 304$ psi (2.1 MPa))
Ambient Temperature effect (Shift from the set range) Change of 86°F (30°C) (*3) (Range from 23 to 131°F {-5 to 55°C})	Combined shift: (including zero and span shifts)	$\pm 0.85\%$	(For $\chi \geq 508$ psi (3.5 MPa))
		$\pm \left(0.35 + 0.5 \times \frac{508}{\chi}\right) \%$	(For $\chi < 508$ psi (3.5 MPa))

Model GTX82G

(Material of wetted parts: Diaphragm; ASTM B575 (Equivalent to Hastelloy C-276))

Reference accuracy (*3)(*4)		$\pm 0.15\%$	(For $\chi \geq 1015$ psi (7 MPa))
		$\pm \left(0.05 + 0.1 \times \frac{1015}{\chi}\right) \%$	(For $\chi < 1015$ psi (7 MPa))
Ambient Temperature effect (Shift from the set range) Change of 86°F (30°C) (*3) (Range from 23 to 131°F {-5 to 55°C})	Combined shift: (including zero and span shifts)	$\pm 0.85\%$	(For $\chi \geq 1015$ psi (7 MPa))
		$\pm \left(0.35 + 0.5 \times \frac{1015}{\chi}\right) \%$	(For $\chi < 1015$ psi (7 MPa))

*3) Within a range of $URV \geq 0$ and $LRV \geq 0$.

*4) Reference accuracy at calibrated condition.

MODEL SELECTION

Model GTX60G(Standard gage pressure)

Model No.:GTX__G - Selection I (I II III IV V VI VII) - Selection II(I II III IV V VI) - Option

Basic Model No.

Measuring span	2.54 to 508 psi (17.5 to 3500kPa)	GTX60G
----------------	-----------------------------------	--------

Selection I

I	Output	4 to 20mA (SFN Communication)	A	
		4 to 20mA (HART Communication)	B	
		4 to 20mA (SFN/HART Bilingual Communication) *1	E	
II	Fill fluid	Regular type (Silicone oil)	A	
		For oxygen service (Fluorine oil)	H	
		For chlorine service (Fluorine oil) *6	J	
III	Material (Meter-body cover, Vent/ Drain plugs)	Meterbody cover	Vent / Drain plugs	
		SCS14A	316 SST	A
		PVC *4*7*8	PVC *4*7*8	C
IV	Material (center body)	316 SST (Diaphragm: 316L SST)	A	
		ASTM B575 (Equivalent to Hastelloy C-276)	B	
		Tantalum *5	C	
		316L SST *5	D	
V	Process connections of reference side	Rc 1/2, with adapter flange *7	A	
		Rc 1/4, with adapter flange	B	
		Rc 1/4, without adapter flange	C	
		1/2 NPT internal thread, with adapter flange *7	D	
		1/4 NPT internal thread, with adapter flange	E	
		1/4 NPT internal thread, without adapter flange	F	
VI	Process installation	Vertical piping, top connection *5 *8	A	
		Vertical piping, bottom connection *5 *8	B	
		Horizontal piping, front connection	C	
VII	Bolt/nut	304 SST	B	

Selection II

			-	
I	Electrical connection	1/2 NPT, Watertight	A	
		M20, Watertight *9	B	
II	Explosion proof	None		XX
		FM Explosion proof		F1
		FM Intrinsically safe		F2
		FM Nonincendive		F5
		ATEX Explosion proof		A1
		ATEX Intrinsically safe		A2
		ATEX Type n		A5
		IECEX Explosion proof,		E1
		IECEX Intrinsically safe		E2
		IECEX Type n		E5
		NEPSI Explosionproof		N1
		NEPSI Intrinsically safe		N2
		NEPSI Type n		N5
III	Indicator	None		X
		With indicator	A	
IV	Paint	Standard		X
		Corrosion-proof		B
		Corrosion-resistant (Silver coating)		D
V	Failure alarm	Upper limit of output at abnormal condition		A
		Lower limit of output at abnormal condition		B
VI	Mounting bracket	None		X
		Carbon steel (L form) *2		3
		304 SST (L form) *2		4
		Carbon steel (Flat form) *3		5
		304 SST (Flat form) *3		6

Note) *1 Not applicable for the combination with code Q1 "Safety transmitter" of option.

*2 Applicable for wetted parts of material (center body); 316 SST and ASTM B575

*3 Applicable for wetted parts of material (center body); Tantalum and 316L SST.

*4 304 SST bolts and nuts material (-B) must be selected when PVC meterbody cover is selected. The max. working pressure is 217 psi (1.5MPa).

*5 In case code C, or D is selected, code A, or B of Process installation should be selected.

*6 In case code J is selected, code C "Tantalum" of Material (meterbody) should be selected.

*7 In case PVC is selected, code A, or D of Process connections should be selected.

*8 In case PVC is selected, code A, or B of Process installation should be selected.

*9 Not applicable for the combination with code F1 "FM Explosion proof" of Explosion proof.

(Continued from previous page)

Model No.:GTX__G-Selection I (I II III IV V VI VII) - Selection II (I II III IV V VI) - **Option**

Option	-
No options	XX
With external Zero/Span adjustment*11	A2
One elbow (left) *6 *7*10	G1
One elbow (right) *6 *7*10	G2
2 elbows *6 *8*10	G3
Long vent/drain plugs	G4
Side vent/drain top *6	G6
Side vent/drain bottom *6	G7
Oil and water free finish	K1
Oil free finish *4	K3
Au Plating Diaphragm	L1
Safety Transmitter *5	Q1
NAMUR NE43 Compliant Output Signal Limits:3.8 to 20.5mA (Output 21.6mA/selected upper limit, 3.6mA/selected lower limit)	Q2
Alarm Output (contact output)	Q7
Custom calibration	R1
Test report	T1
Mill certificate	T2
Traceability certificate	T4
NACE certificate *9	T5
Non SI Unit	W1

- Note) *4 No need to select when Fill Fluid code H, or J is selected.
 *5 Not applicable for the combination with code E of Output and code A2, or Q7 of Option.
 *6 Not applicable for the combination with code A, or B of Process installation.
 *7 Not applicable for the combination with code F1 "FM Explosion proof" of Explosion proof.
 *8 Not applicable for any Explosion proof. Please select code F1 "None" of Explosion proof.
 *9 Applicable for "ASTM B575", code B of Material (center body).
 *10 Not applicable for the combination with code B "M20, Watertight" electrical connection.
 *11 Not applicable for the combination with code X "None" of Indicator. Please select "With indicator".

Model GTX71G(High gage pressure)

Model No.:GTX__G - Selection I (I II III IV V VI VII) - Selection II(I II III IV V VI) - Option

Basic Model No.

Measuring span	101 to 203 psi (0.7 to 14MPa)	GTX71G
----------------	-------------------------------	--------

Selection I

I	Output	4 to 20mA (SFN Communication)	A
		4 to 20mA (HART Communication)	B
		4 to 20mA (SFN/HART Bilingual Communication) *1	E
II	Fill fluid	Regular type (Silicone oil)	A
		For oxygen service (Fluorine oil)	H
		For chlorine service (Fluorine oil) *7	J
III	Material (Meter-body cover, Vent/ Drain plugs)	Meterbody cover	Vent / Drain plugs
		SCS14A	316 SST
IV	Material (center body)	316 SST (Diaphragm: 316L SST)	A
		ASTM B575 (Equivalent to Hastelloy C-276)	B
		Tantalum *6	C
		316L SST *6	D
V	Process connections of reference side	Rc 1/2, with adapter flange	A
		Rc 1/4, with adapter flange	B
		Rc 1/4, without adapter flange	C
		1/2 NPT internal thread, with adapter flange	D
		1/4 NPT internal thread, with adapter flange	E
		1/4 NPT internal thread, without adapter flange	F
VI	Process installation	Vertical piping, top connection *6	A
		Vertical piping, bottom connection *6	B
		Horizontal piping, front connection	C
VII	Bolt/nut	Carbon steel	A
		304 SST *5	B
		630 SST	C

Selection II

I	Electrical connection	1/2 NPT, Watertight	A
		M20, Watertight *8	B
II	Explosion proof	None	XX
		FM Explosion proof	F1
		FM Intrinsically safe	F2
		FM Nonincendive	F5
		ATEX Explosion proof	A1
		ATEX Intrinsically safe	A2
		ATEX Type n	A5
		IECEX Explosion proof,	E1
		IECEX Intrinsically safe	E2
		IECEX Type n	E5
		NEPSI Explosionproof	N1
		NEPSI Intrinsically safe	N2
NEPSI Type n	N5		
III	Indicator	None	X
		With indicator	A
IV	Paint	Standard	X
		Corrosion-proof	B
		Corrosion-resistant (Silver coating)	D
V	Failure alarm	Upper limit of output at abnormal condition	A
		Lower limit of output at abnormal condition	B
VI	Mounting bracket	None	X
		Carbon steel (L form) *2	3
		304 SST (L form) *2	4
		Carbon steel (Flat form) *3	5
		304 SST (Flat form) *3	6

Note) *1 Not applicable for the combination with code Q1 "Safety transmitter" of option.

*2 Applicable for wetted parts of material (center body);316 SST and ASTM B575

*3 Applicable for wetted parts of material (center body);Tantalum,316L SST.

*5 When 304 SST bolt/nut is selected, max working pressure rating is 1450 psi (10MPa)

*6 In case code C, or D is selected, code A, or B of Process installation should be selected.

*7 In case code J is selected, code C "Tantalum" of Material (meterbody) should be selected.

*8 Not applicable for the combination with code F1 "FM Explosion proof" of Explosion proof.

(Continued)

(Continued from previous page)

Model No.:GTX__G-Selection I (I II III IV V VI VII) - Selection II (I II III IV V VI) - **Option**

Option		
	No options	XX
	With external Zero/Span adjustment*11	A2
	PED (97/23/EC) Conformity *1 *2 *3	F1
	One elbow (left) *6 *7*10	G1
	One elbow (right) *6 *7*10	G2
	2 elbows *6 *8*10	G3
	Long vent/drain plugs	G4
	Side vent/drain top *6	G6
	Side vent/drain bottom *6	G7
	Oil and water free finish	K1
	Oil free finish *4	K3
	Au Plating Diaphragm	L1
	Safety Transmitter *5	Q1
	NAMUR NE43 Compliant Output Signal Limits:3.8 to 20.5mA (Output 21.6mA/selected upper limit, 3.6mA/selected lower limit)	Q2
	Alarm Output (contact output)	Q7
	Custom calibration	R1
	Test report	T1
	Mill certificate	T2
	Traceability certificate	T4
	NACE certificate *9	T5
	Non SI Unit	W1

- Note) *1 "PED Conformity" is not applicable for the combination with FM, IECEx, KOSHA or NEPSI approvals.
 *2 "PED Conformity" is not applicable for the combination with GTX60G.
 *3 Not applicable for the combination with "304 SST Bolts/Nuts".
 *4 No need to select when Fill Fluid code H, or J is selected.
 *5 Not applicable for the combination with code E of Output and code A2, or Q7 of Option.
 *6 Not applicable for the combination with code A, or B of Process installation.
 *7 Not applicable for the combination with code F1 "FM Explosion proof" of Explosion proof.
 *8 Not applicable for any Explosion proof. Please select code F1 "None" of Explosion proof.
 *9 Applicable for "ASTM B575", code B of Material (center body).
 *10 Not applicable for the combination with code B "M20, Watertight" electrical connection.
 *11 Not applicable for the combination with code X "None" of Indicator. Please select "With indicator".

Model GTX82G(High gage pressure)

Model No.:GTX__G - Selection I (I II III IV V VI VII) - Selection II(I II III IV V VI) - Option

Basic Model No.

Measuring span	101 to 6091 psi (0.7 to 42MPa)	GTX82G
----------------	--------------------------------	--------

Selection I

I	Output	4 to 20mA (SFN Communication)	A
		4 to 20mA (HART Communication)	B
		4 to 20mA (SFN/HART Bilingual Communication) *1	E
II	Fill fluid	Regular type (Silicone oil)	A
		For oxygen service (Fluorine oil)	H
III	Material (Meter-body cover, Vent/ Drain plugs)	Meterbody cover	Vent / Drain plugs
		316 SST	
IV	Material (center body)	316 SST (Diaphragm: 316L SST)	A
		ASTM B575 (Equivalent to Hastelloy C-276)	B
V	Process connections of reference side	Rc 1/4, without adapter flange	C
		1/4 NPT internal thread, without adapter flange	F
VI	Process installation	Vertical piping, top connection	A
		Vertical piping, bottom connection	B
VII	Bolt/nut	Carbon steel	A
		304 SST *5	B
		630 SST	C

Selection II

			-
I	Electrical connection	1/2 NPT, Watertight	A
		M20, Watertight *6	B
II	Explosion proof	None	XX
		FM Explosion proof	F1
		FM Intrinsically safe	F2
		FM Nonincendive	F5
		ATEX Explosion proof	A1
		ATEX Intrinsically safe	A2
		ATEX Type n	A5
		IECEX Explosion proof,	E1
		IECEX Intrinsically safe	E2
		IECEX Type n	E5
		NEPSI Explosionproof	N1
		NEPSI Intrinsically safe	N2
		NEPSI Type n	N5
III	Indicator	None	X
		With indicator	A
IV	Paint	Standard	X
		Corrosion-resistant	A
		Corrosion-proof	B
		Corrosion-resistant (Silver coating)	D
V	Failure alarm	Upper limit of output at abnormal condition	A
		Lower limit of output at abnormal condition	B
VI	Mounting bracket	None	X
		Carbon steel (Flat form)	5
		304 SST (Flat form)	6

Note) *1 Not applicable for the combination with code Q1 "Safety transmitter" of option.

*5 When 304 SST bolt/nut is selected, max working pressure rating is 3335 psi (23MPa).

*6 Not applicable for the combination with code F1 "FM Explosion proof" of Explosion proof.

(Continued)

(Continued from previous page)

Model No.: GTX__G-Selection I (I II III IV V VI VII) - Selection II(I II III IV V VI) - **Option**

Option	-
No options	XX
With external Zero/Span adjustment*11	A2
PED (97/23/EC) Conformity *1 *2 *3	F1
One elbow (left) *6 *7*10	G1
One elbow (right) *6 *7*10	G2
2 elbows *6 *8*10	G3
Long vent/drain plugs	G4
Side vent/drain top *6	G6
Side vent/drain bottom *6	G7
Oil and water free finish	K1
Oil free finish *4	K3
Au Plating Diaphragm *12	L1
Safety Transmitter *5	Q1
NAMUR NE43 Compliant Output Signal Limits:3.8 to 20.5mA (Output 21.6mA/selected upper limit, 3.6mA/selected lower limit)	Q2
Alarm Output (contact output)	Q7
Custom calibration	R1
Test report	T1
Mill certificate	T2
Traceability certificate	T4
NACE certificate *9	T5
Non SI Unit	W1

- Note) *1 "PED Conformity" is not applicable for the combination with FM, IECEx, KOSHA or NEPSI approvals.
 *2 "PED Conformity" is not applicable for the combination with GTX60G.
 *3 Not applicable for the combination with "304 SST Bolts/Nuts".
 *4 No need to select when Fill Fluid code H, or J is selected.
 *5 Not applicable for the combination with code E of Output and code A2, or Q7 of Option.
 *6 Not applicable for the combination with code A, or B of Process installation.
 *7 Not applicable for the combination with code F1 "FM Explosion proof" of Explosion proof.
 *8 Not applicable for any Explosion proof. Please select code F1 "None" of Explosion proof.
 *9 Applicable for "ASTM B575", code B of Material (center body).
 *10 Not applicable for the combination with code B "M20, Watertight" electrical connection.
 *11 Not applicable for the combination with code X "None" of Indicator. Please select "With indicator".
 *12 Not applicable for the combination with "Tantalum" of diaphragm Material.

DIMENSIONS

Model GTX60G (Material (center body): 316 SST, ASTM B575)

Process Connection : Front Side

(Unit : mm)

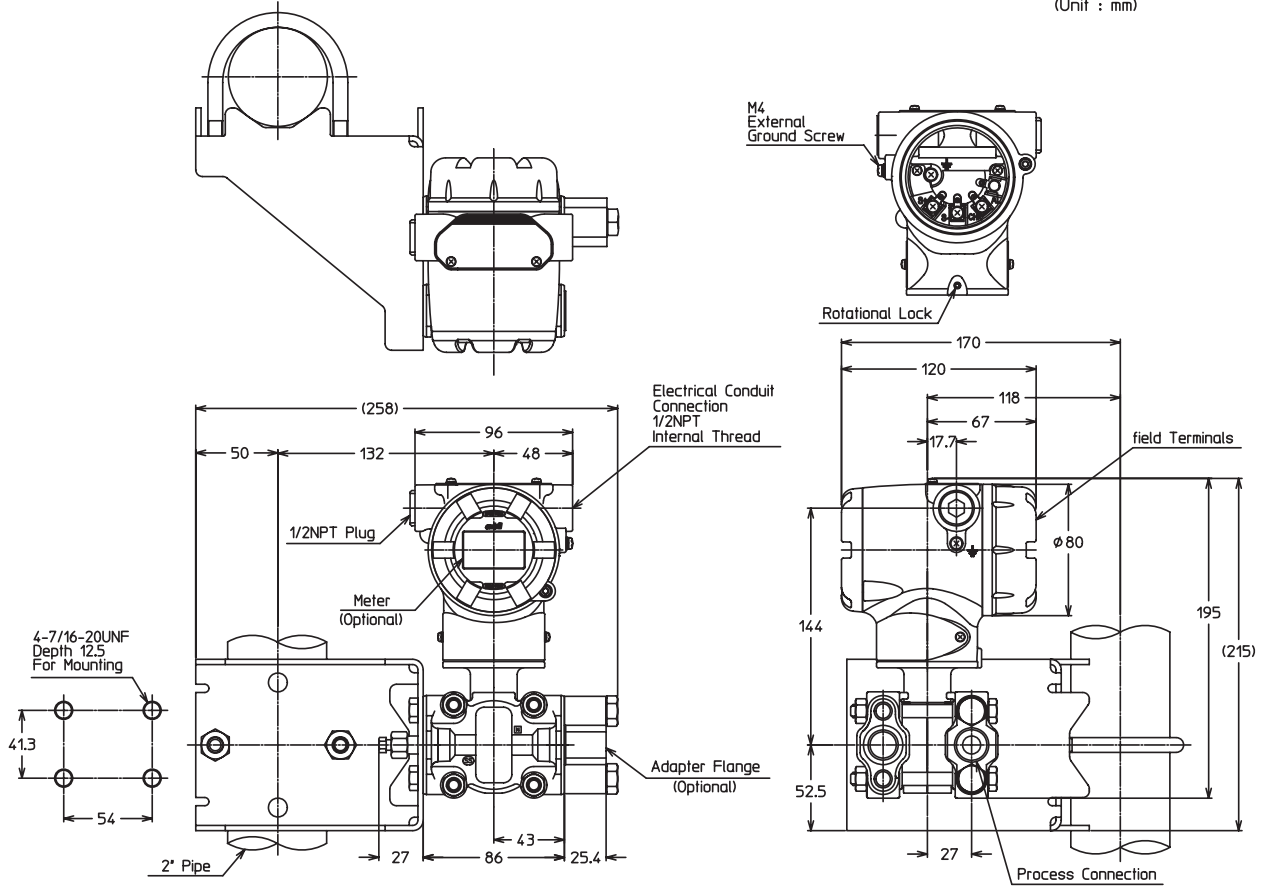

Process Connection : Top or Bottom Side

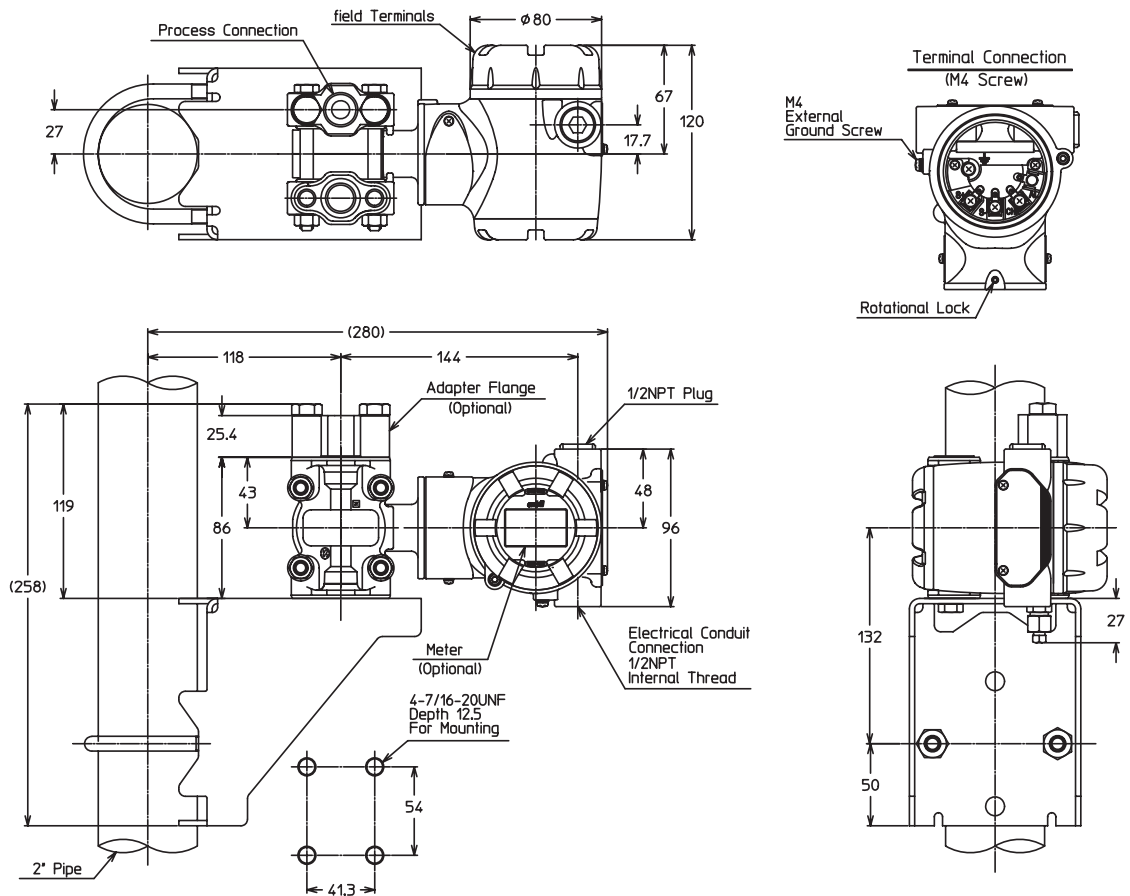

Model GTX71G (Material (center body): 316 SST, ASTM B575)

Process Connection : Front Side

GTX_Gauge

(Unit : mm)

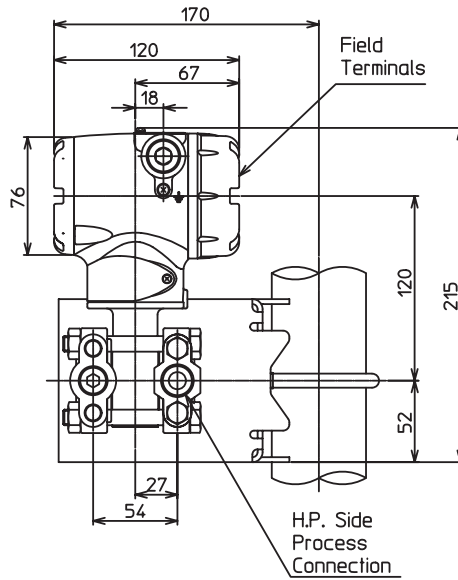
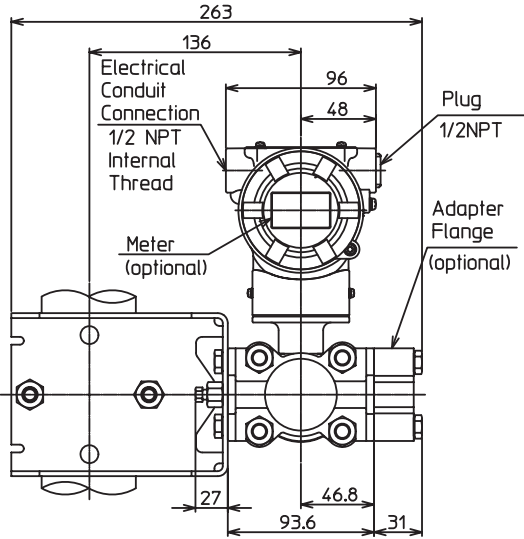
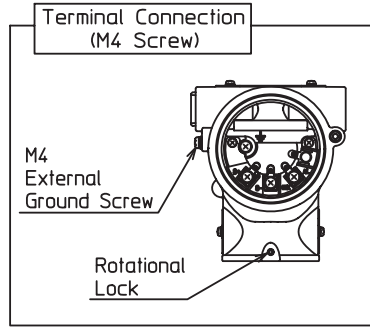
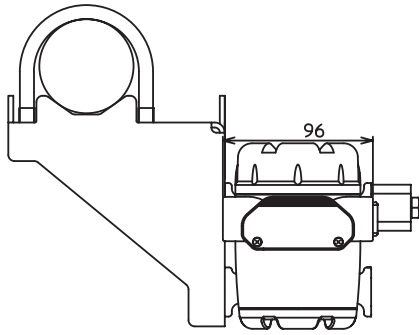

Process Connection : Top or Bottom Side

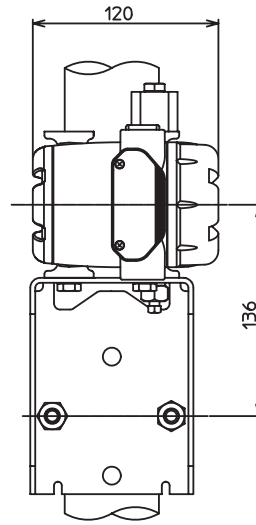
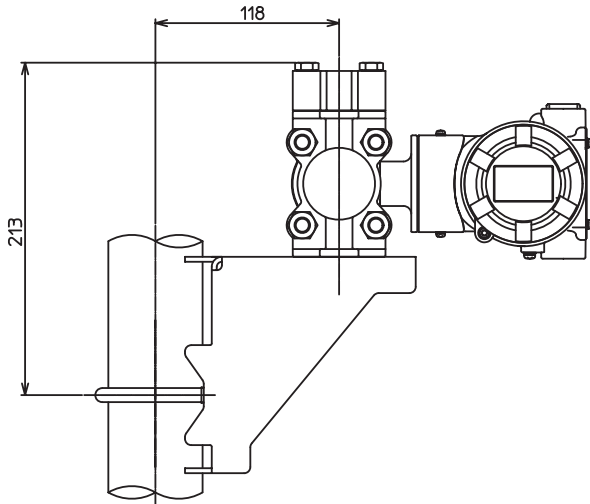
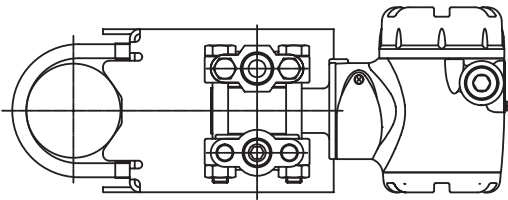

Model GTX82G

(Unit : mm)

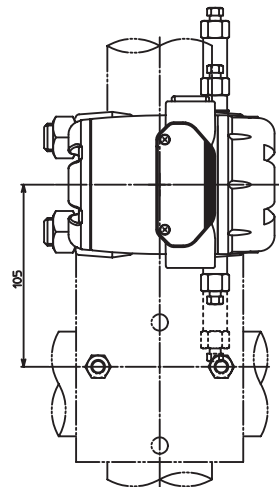
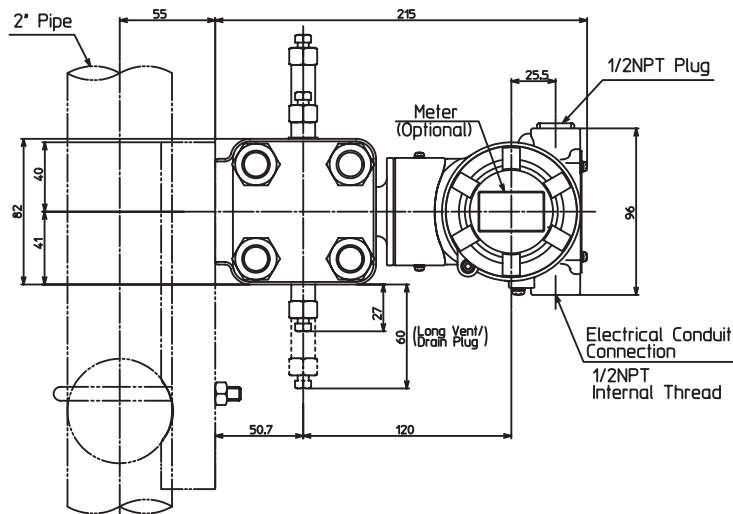
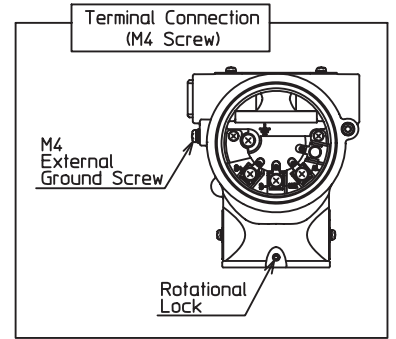
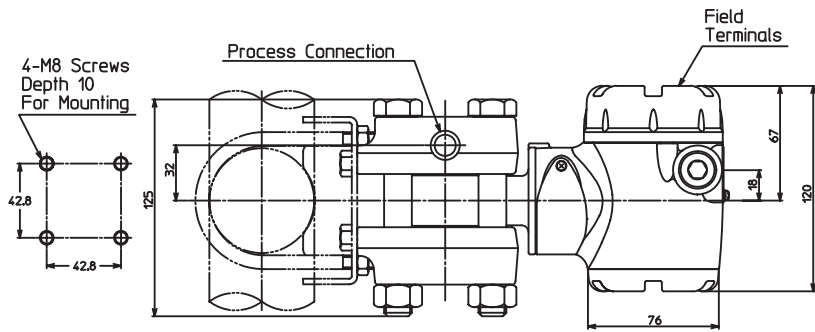

Model GTX60G/71G (Material (center body): Tantalum, 316L SST)

Process connection: Top or bottom side

(Unit : mm)

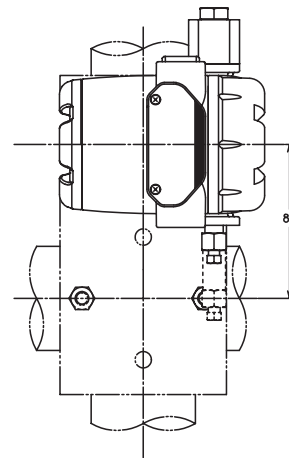
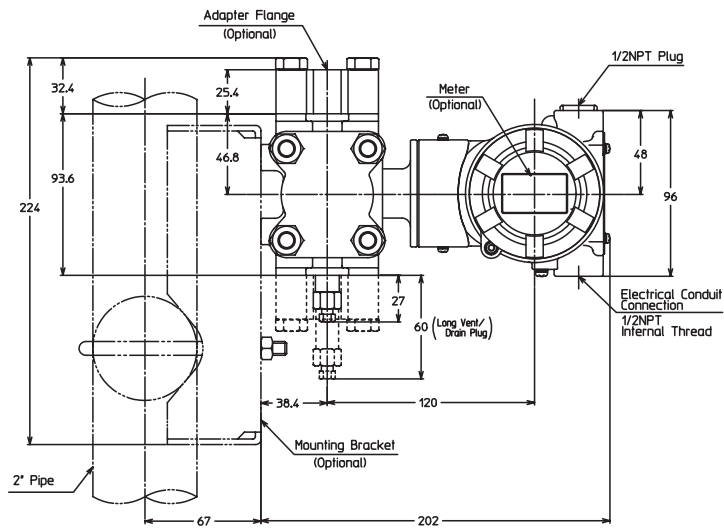
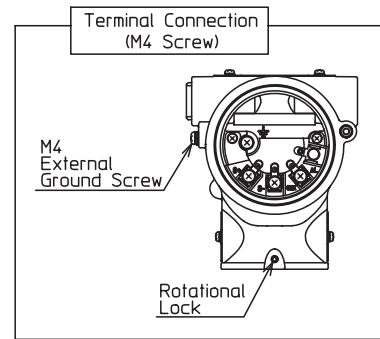
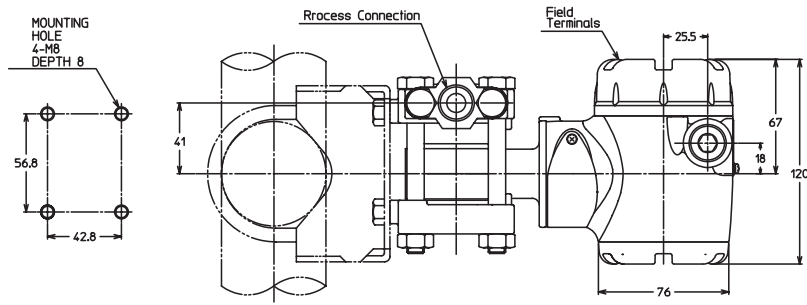

Model GTX60G(Material (Meter body cover, Vent/Drain plugs: PVC)

Process connection: Top or bottom side

(Unit : mm)

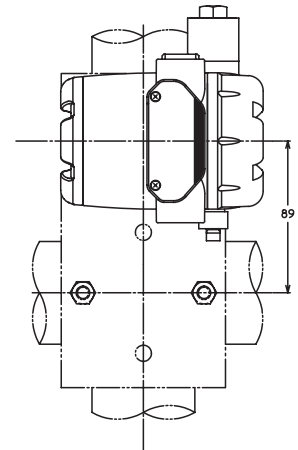
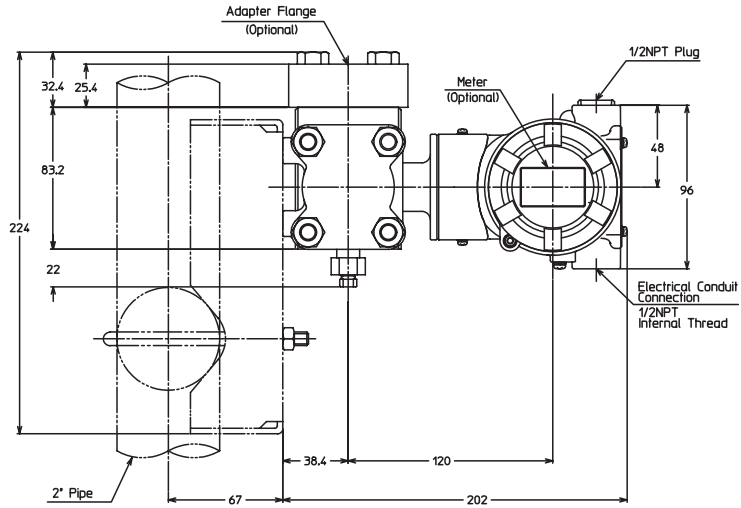
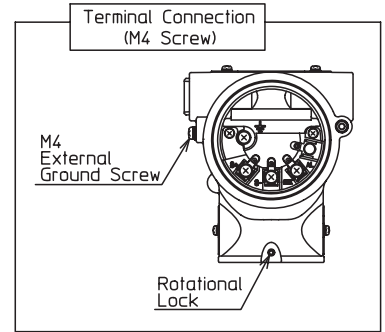
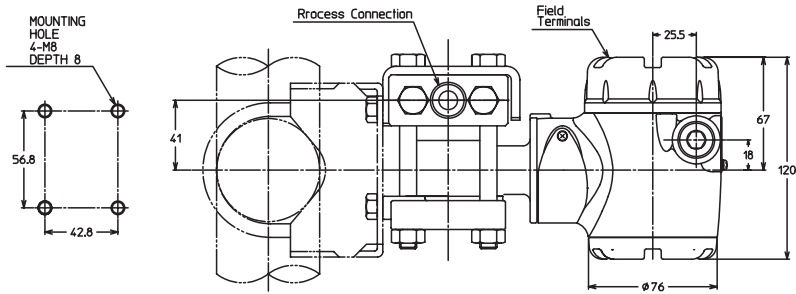

Note

Note

Specifications are subject to change without notice.

azbil

Yamatake Corporation
Advanced Automation Company

1-12-2 Kawana, Fujisawa-shi
Kanagawa-ken 251-8522 Japan

URL:<http://www.azbil.com>

No part of this publication may be reproduced or duplicated without the prior written permission of Yamatake Corporation.

Aug. 2008–Y/Y
Nov. 2009 (rev.2)–Y/Y
Reference: SS2-GTX00G-0100(rev.7)