

# CheckAll<sup>®</sup> VALVE



**Serving Customers Around  
the World for Over 50 years.**



**INSERT**



**HOUSED**



**TUBING**



**MINI-CHECK**



## FOUR SERIES OF CHECK-ALL VALVES

For nearly every possible application and need, you can economically install a **Check-All** valve. Lightweight, efficient, and rugged, every **Check-All** valve is designed and built to perform to exact needs and specifications. There are a wide variety of standard valves immediately available from stock, as well as other valves of various materials and designs. We are staffed to provide you with quality products and technical services to meet your application needs. Please feel free to put us to work on your project.

We inspect all **Check-All** valves at least five times: . . . beginning with design, during manufacture, under use conditions through testing, with a thorough inspection, and finally, as your order is packaged and shipped. This constant and very precise program of inspection, test, and re-check assures you a high quality product every time. You can be confident that your **Check-All** valve is the finest you can get and that it will function exactly as you want. . . and as you need it to function.

Check-All Valve Mfg. Co.  
1800 Fuller Road  
West Des Moines, IA 50265 U.S.A.  
Phone: 515-224-2301  
Fax: 515-224-2326  
Website: [www.checkall.com](http://www.checkall.com)  
E-mail: [sales@checkall.com](mailto:sales@checkall.com)

# C O N T E N T S

Introduction to Company and Products . . . . .	2
Order Information . . . . .	4
Insert Series Check Valves	
Flange Insert . . . . .	6
Lined Pipe Insert . . . . .	10
Straight Sided Insert . . . . .	12
Glass Pipe Insert . . . . .	14
 Sanitary Check . . . . .	16
 Sanitary Check Disassembly for Cleaning Instructions . . . . .	18
Sanitary Cartridge . . . . .	20
Sanitary Insert . . . . .	22
Union Insert . . . . .	24
Housed Series Check Valves	
Bushing . . . . .	26
Connector . . . . .	28
Horizontal-Vertical, Flanged & Drilled . . . . .	30
Horizontal-Vertical, Flanged & Drilled PTFE Lined . . . . .	32
Universal Low Pressure . . . . .	34
Universal High Pressure . . . . .	36
Universal Socket Weld . . . . .	38
Mini-Check Series Check Valves . . . . .	40
Tubing Series Check Valves	
Tubing Check Valve . . . . .	42
Tubing Check Valve Flared . . . . .	44
Technical Data . . . . .	46
Application Guidelines . . . . .	47
Installation and Operating Instructions . . . . .	48
Body Material Definition for Check-All Valve Products . . . . .	50
Pressure Equipment Directive (PED 97/23/EC) Conformance Statement . . . . .	52
Notes . . . . .	54
Manufacturer's Terms and Conditions of Sale . . . . .	55

---

***In the beginning . . .*** the first **Check-All** valve was designed and built for use as a pump foot valve; the year was 1958. Since then **Check-All** has grown from an idea to a reality; from one valve to many series of valves; from one use to multiple uses; from one material to a variety of materials and from one man to a factory. **Check-All** has grown in all respects — but one element remains the same — SERVICE TO EACH CUSTOMER. We will never permit this to change.

*Design Features* — The complete line of **Check-All** valves are in-line spring-loaded piston-type check valves. Many series are available to provide check valves for practically every service application. All valves are available with *metal to metal* or *soft seats*. Sizes range from 1/8" NPT to 20 inch flanged connections. Pressure ratings are available from *full vacuum* to *10,000 psi*. Special materials available are Titanium, *HASTELLOY®*, *MONEL®*, Alloy 20, and many others. A wide range of spring settings is available for all valves. Fluoropolymer (FEP) encapsulated springs are available for special corrosion applications. The following are some of the reasons **Check-All** is an outstanding source for all your check valve, vacuum breaker, and low pressure relief applications:

**SILENT** — engineered for silent operation! Check-All valves close quickly and smoothly to minimize hammer noise.

**ORIFICE SIZE** — engineered from empirical data to give a minimum pressure drop over the full flow range of the valve.

**BASIC DESIGN** — streamlined so that fluid flows through the valve over smooth contoured surfaces with a minimum change in direction, therefore minimized pressure drop.

**INDUCED TURBULENCE** — on seating surfaces just before the valve closes, insures positive sealing by removing minute foreign particles suspended in the fluid.

**SEATING SURFACES** — all metal valves are mated and precision lapped to insure effective sealing. The parts remain mated through the assembly process.

**DESIGNED** — to function *equally well* in either a vertical or horizontal position, with proper spring selection.

**DESIGNED** — to *reduce* installation costs, the Insert series check valves easily fit into existing line components which reduces both initial cost and installation time.

**DESIGNED** — to *reduce* maintenance costs, the Check-All design is simple, rugged and efficient. The seating surfaces are parallel to each other thereby eliminating the excessive wear occurring in plug, cone and ball seats.

**DESIGNED** — with the spring upstream of the seat, strategically placing it outside any mixing and potentially aggressive solutions.

**VERSATILE**—Check-All valves also can be used as **LOW PRESSURE RELIEF VALVES** and **VACUUM BREAKERS**.

## Certifications:

**ISO 9001-2000** Check-All Valve is an ISO 9001-2000 Certified company. Our certificate number is FM 40858 and is issued by The British Standards Institution (BSI). This certification indicates that Check-All products are designed, manufactured and distributed in accordance with ISO 9001 requirements. That means when you order Check-All Valve products you are assured of receiving the highest quality check valves; consistently and on-time.

 **Sanitary Standards** The Check-All style 3SC check valve is compliant with 3-A Sanitary Standards for Vacuum Breakers and Check Valves for Milk and Milk Products, Number 58-00 and has been Third Party Verified by a Certified Conformance Evaluator. Among other requirements, this is a standard that requires a 32 Ra finish and specified groove angles and depths, all for sanitary purposes. Consult the factory if finer surface finishes are required.

**Canadian Registration Number** Check-All Valve also has obtained a Canadian Registration Number (0C3651.5R1C) for many of its products. The CRN is required for some products to be installed in certain applications in Canada. Check-All has registration in all provinces and territories of Canada. Consult the factory if you require a valve with a CRN.

**CE (PED 97/23/EC) Conformance** Many Check-All Valve products conform to the Pressure Equipment Directive (PED 97/23/EC). Our certificate number is CE62128 and is issued by The British Standards Institution (BSI) who is our Notified Body for conformance under assessment Module H (full quality system). Please see page 52 for additional information regarding CE conformance.

# ORDER INFORMATION

Also See Valve Application Guidelines on Page 47

**WARNING:** DO NOT INSTALL ON THE DISCHARGE OF A RECIPROCATING AIR COMPRESSOR OR DIRECTLY ON THE OUTLET SIDE OF AN ELBOW. VALVES ARE DESIGNED FOR FULLY DEVELOPED FLOW.

**Check-All valves are** completely described by — **Style** designation and combinations of **Letters** and **Numbers**. The appropriate combinations will designate: **Style, Size, Body Material, Seat Material, Spring Cracking Pressure, and Spring Material.**

## A. Materials:

Internal materials may differ from body materials. Consult the factory for details. Material selection for a specific application is the responsibility of the customer. See page 50 for additional comments regarding material selection.

### 1. Body Materials:

SS - 316 Stainless Steel (-320°F to 700°F)	TF - Fluoropolymer (PTFE) (-320°F to 400°F)
BR - Brass (-320°F to 400°F)	PV - PVC (+32°F to 150°F)
CS - Carbon Steel (-20°F to 700°F)	A2 - Alloy 20 (-320°F to 600°F)
MO - <i>MONEL</i> <sup>®</sup> Alloy (-320°F to 500°F)	HC - <i>HASTELLOY</i> <sup>®</sup> C Alloy (-320°F to 1000°F)
TI - Titanium (-75°F to 500°F)	HB - <i>HASTELLOY</i> <sup>®</sup> B Alloy (-320°F to 800°F)

### 2. Seats Materials:

All valve seats are integral and can be supplied either with an o-ring (soft seat) or without an o-ring (metal-to-metal seat). Whether the valve body is metal or plastic, the term “metal-to-metal” is used for seats without o-rings. Metal-to-metal seats are the same material as the valve body unless otherwise specified. ALL O-RING SEATS HAVE A MAXIMUM PRESSURE RATING OF 1500 PSI. Temperature ranges given are for ideal service conditions and may vary. FDA compounds are also available for some seat materials. Consult the factory for assistance.

AS — AFLAS <sup>®</sup> (-20°F to 400°F)	NE — Neoprene (-65°F to 260°F)
BN — Buna-N (-65°F to 250°F)	TF — Fluoropolymer (PTFE) (-320°F to 400°F) <i>TF not available for plastic valves.</i>
EP — EPDM (-70°F to 300°F)	
KZ — KALREZ <sup>®</sup> (0°F to 500°F)	VT — VITON <sup>®</sup> (-10°F to 400°F)
MT — Metal-to-Metal (or same as body material)	

## B. Seat Leakage:

Resilient soft seats are required for “bubble tight” shutoff. Consult the factory for information on metal-to-metal or PTFE seats. Metal-to-metal and PTFE seats are not resilient. See page 47 for allowable leakage rates.

## C. Springs:

All standard springs are 316 stainless steel unless noted otherwise. Several cracking pressure options are available for each valve. Spring sizes are defined by the orifice diameter of the valve.

SS	—	316 Stainless Steel (-320°F to 400°F)
PH	—	17-7 PH Stainless Steel (-20°F to 400°F)
HC	—	<i>HASTELLOY</i> ® C Alloy (-320°F to 400°F)
HB	—	<i>HASTELLOY</i> ® B Alloy (-320°F to 400°F)
MO	—	<i>MONEL</i> ® Alloy (-320°F to 400°F)
IX	—	<i>INCONEL</i> ® Alloy X750 (-320°F to 700°F)
TI	—	Titanium Beta C (-75°F to 550°F)

Consult the factory for other available spring materials or higher temperature applications. Higher alloy material valves use higher alloy springs.

## D. Fluoropolymer (FEP) Encapsulated Springs:

Springs are incased in heat shrinkable FEP tubing. The ends of the tubing are plugged with FEP and sealed. When ordering FEP encapsulated springs add the letter “T” as a suffix to the cracking pressure and spring material specified. FEP encapsulation may reduce flow capacity and the cracking pressure may vary. Temperature range for FEP encapsulation material is -320°F to 400°F. Some springs for .348 and .464 orifice diameters are not available with FEP encapsulation. Consult the factory for a substituted spring.

## E. Special Springs:

Special alloys or special cracking pressures are available for all valves. Higher cracking pressure springs may reduce flow capacity. Consult the factory for price and delivery.

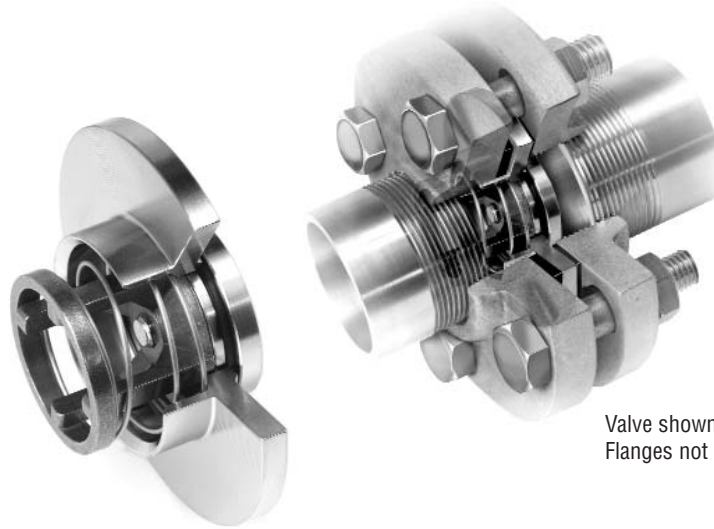
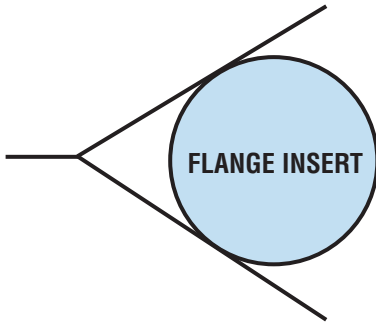

Valve shown in flanges.  
Flanges not included.

**Flange Insert** valves are the ultimate check valves in flanged systems. They provide the simplest most economical way to install check valves in a piping system. The valve body automatically positions the valve and holds it in place while bolts are being installed and tightened. All that is required is two gaskets in place of the one normally used in a flanged joint. See page 48 or consult the factory for additional installation guidelines.

**Flange Insert** valves are designed to fit between two mating ANSI flanges. The “Spring Housing”, designated by the “A” dimension, is designed to be inserted into the upstream pipe, thereby centering it in the pipe. Therefore, there must be clearance between the spring housing and the pipe or flange. Generally speaking, the FIV Class 150 and 300 valves (F1) are designed for standard schedule pipe or Class 150 or 300 flanges, and the FIV Class 600 (F6) valves are designed for schedule 80 pipe or Class 600 flanges.

**Flange Insert** valves can be used as check valves, low pressure relief valves, and vacuum breakers by simply using different spring settings.

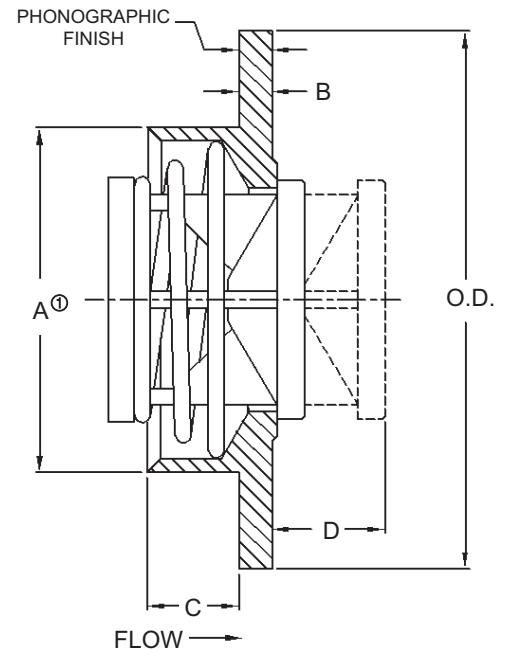

Body Material <sup>②</sup>	Nominal Pipe Size	Non-Shock Pressure Rating		
		ANSI Class 150	ANSI Class 300	ANSI Class 600
316 Stainless Steel (SS) Carbon Steel (CS) Alloy 20 (A2) Hastelloy® C (HC) Hastelloy® B (HB) Mone® (MO) Titanium (TI)	1/2 - 4	X	X	X
	5 - 20	X		
	1/2 - 4	X	X	
	5 - 20	X		
	1/2 - 1-1/2		55 PSIG @ 100°F <sup>③</sup>	
PTFE (TF)	2 - 6		20 PSIG @ 100°F <sup>③</sup>	
	1/2 - 6		200 PSIG @ 100°F <sup>③</sup>	

<sup>①</sup>Check “A” dimension for clearance with pipe ID. Generally “A” dimension is designed for use in standard schedule pipe for class 150 & 300 valves (F1). Order class 600 (F6) valves for schedule 80 pipe.

<sup>②</sup>See page 50 for material grade information.

<sup>③</sup>Consult the factory for reduced P-T rating above 100°F. Standard spring material is 316 Stainless Steel.

# HOW TO ORDER CHECK-ALL STYLE FIV (F1, F6, FP)

BODY MATERIAL	
ALLOY 20	= A2
BRASS	= BR
CARBON STEEL	= CS
HASTELLOY® B	= HB
HASTELLOY® C	= HC
MONEL®	= MO
PVC	= PV
316SS	= SS
PTFE	= TF
TITANIUM	= TI

**See p. 4 for Temperature ratings**

SPRING CRACKING PRESSURES			
Replace "X" with actual desired setting. Must use decimal as a character.			
(PSI)	FORMAT		
0.000 TO 0.999	= .XXX		
1.00 TO 9.99	= X.XX		
10.0 TO 99.9	= XX.X		
NO SPRING	= NOSPRG		
STANDARD CRACKING PRESSURES <sup>①</sup>			
.125	.500	1.50	3.50
(Sizes D-N Only)	(Sizes D-N Only)	(Sizes D-J Only)	(Sizes D-J Only)

**Note: Many other cracking pressures are available. Consult factory.**

SPECIAL OPTIONS
T = FEP ENCAPSULATED SPRING
<b>See p. 5 for Temperature rating</b>
Contact the factory for more options



VALVE STYLE
Class 150 & 300 = F1 (FIT UP TO SCH 40 PIPE)
Class 600 = F6 (FIT UP TO SCH 80 PIPE)
PTFE & PVC = FP

SIZE (SEE BELOW)
---------------------

SEAT MATERIAL <sup>②</sup>	
AFLAS®	= AS
BUNA-N	= BN
EPDM	= EP
KALREZ®	= KZ
"METAL-TO-METAL" <sup>③</sup>	= MT
NEOPRENE	= NE
PTFE	= TF
VITON®	= VT

**See p. 4 for Temperature ratings**

SPRING MATERIAL	
316 SS	= SS
HASTELLOY® C	= HC
HASTELLOY® B	= HB
INCONEL® X-750	= IX
MONEL®	= MO
17-7PH SS	= PH
TITANIUM	= TI

**See p. 5 for Temperature ratings**

STYLE F1 (All Metals) SIZES	
1/2	= D
3/4	= F
1	= H
1-1/4	= I
1-1/2	= J
2	= K
2-1/2	= L
3	= M
4	= N
5	= O
6	= P
8	= Q
10	= R
12	= S
14	= T
16	= U
18	= V
20	= W

STYLE F6 (Except Brass) SIZES	
1/2	= D
3/4	= F
1	= H
1-1/4	= I
1-1/2	= J
2	= K
2-1/2	= L
3	= M
4	= N

STYLE FP (PTFE or PVC Only) SIZES	
1/2	= D
3/4	= F
1	= H
1-1/4	= I
1-1/2	= J
2	= K
3	= M
4	= N
6	= P

**Note: Consult the factory for an optional Flag Tag which indicates that a check valve is present in the line.**

Listed above are the most common material selections. Please contact the factory for additional options.

<sup>①</sup>.500 PSI is the only standard cracking pressure for spring materials other than Stainless Steel. Cracking pressure tolerance is +/- 15%. .125 PSI springs are not recommended for installations with flow vertical down.  
<sup>②</sup>PTFE seats are not resilient. See page 47 for allowable leakage rates.  
<sup>③</sup>For plastic valves, seat is the same as body.

See Diagram on Page 6

**FIV (F1, F6, FP) Dimensions**

Nominal Pipe Size	Size Code	ANSI Rating & Material	A	B	C	D <sup>①</sup>	O.D.	Orifice <sup>②</sup> Diameter
1/2	D	150 & 300 600 PTFE & PVC	0.605 N/A 0.600	1/4	0.26 N/A 0.27	0.53	1-3/8	0.348
3/4	F	150 & 300 600 PTFE & PVC	0.762 0.719 0.720	1/4	0.26 0.24 0.26	0.61	1-3/4	0.464
1	H	150 & 300 600 PTFE & PVC	1.000 0.922 0.930	1/4	0.36 0.32 0.36	0.78	2	0.593
1-1/4	I	150 & 300 600 PTFE & PVC	1.340 1.234 1.240	1/4	0.44 0.39 0.44	0.85	2-1/2	0.890
1-1/2	J	150 & 300 600 PTFE & PVC	1.570 1.490 1.490	1/4	0.44 0.40 0.50	1.01	2-7/8	1.135
2	K	150 & 300 600 PTFE & PVC	2.005 1.890 1.890	1/4	0.49 0.43 0.52	1.19	3-5/8	1.385
2-1/2	L	150 & 300 600	2.407 2.266	1/4	0.66 0.59	1.43	4-1/8	1.555
3	M	150 & 300 600 PTFE & PVC	3.006 2.844 2.865	5/16	0.70 0.64 0.73	1.59	5	2.025
4	N	150 & 300 600 PTFE & PVC	3.964 3.766 3.766	3/8	1.00 0.96 1.00	1.91	6-3/16	2.560
5	O	150	4.985	1/2	1.07	2.12	7-5/16	3.280
6	P	150 PTFE & PVC	6.003 5.700	3/8 9/16	1.52 1.55	2.46	8-1/2	3.875
8	Q	150	7.919	1/2	2.27	3.30	10-5/8	5.110
10	R	150	9.958	1/2	2.84	3.47	12-3/4	6.380
12	S	150 Brass Other Metals	11.876	5/8 1/2	3.12 3.24	4.14	15	7.670
14	T	150 Brass Other Metals	13.062	11/16 1/2	3.18 3.37	4.42	16-1/4	8.460
16	U	150 Brass Other Metals	14.938	3/4 9/16	3.69 3.88	5.02	18-1/2	9.650
18	V	150 Brass Other Metals	16.814	7/8 5/8	3.87 4.12	5.60	21	10.860
20	W	150 Brass Other Metals	18.750	15/16 11/16	3.88 4.13	6.23	23	12.110

① Maximum nominal dimension for a fully open valve with no spring.

② Due to molding process, orifice in plastic valves may vary.

Sizes 5" and larger are only available in class 150. Consult the factory if using Schedule 80 pipe.

**Flange Insert**  
Flow Curves assume Schedule 40 pipe  
For Water at 72°F

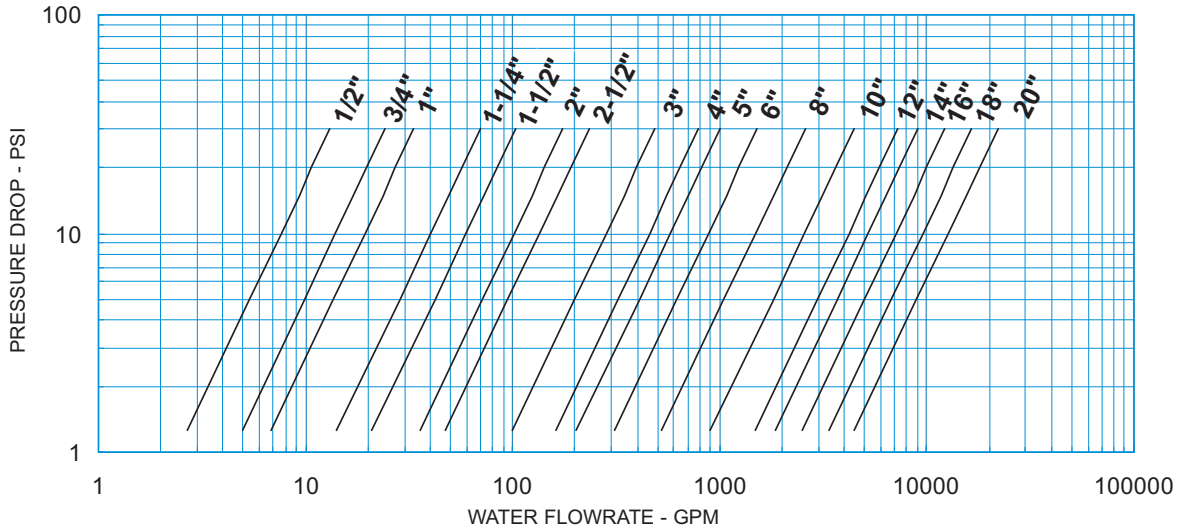

**Note:** All flow curves and Cv values presume the valves are fully open with 1/2 PSI cracking pressure springs. Consult the factory for more information.

STYLE FIV (F1, F6, FP) C <sub>v</sub> VALUES & VALVE WEIGHTS					
C <sub>v</sub>	SIZE	SS & CS	BRASS	PTFE	PVC
2.4	1/2	1.7 oz.	1.9 oz.	0.5 oz.	0.3 oz.
4.4	3/4	2.9 oz.	3.2 oz.	0.8 oz.	0.5 oz.
6.1	1	4.2 oz.	4.6 oz.	1.1 oz.	0.7 oz.
12.7	1-1/4	7.0 oz.	7.4 oz.	1.9 oz.	1.4 oz.
18.8	1-1/2	9.5 oz.	9.8 oz.	2.6 oz.	1.7 oz.
32.0	2	16.3 oz.	17.3 oz.	3.8 oz.	2.6 oz.
42.5	2-1/2	1.4 lb.	1.5 lb.	---	---
89.0	3	2.3 lb.	2.6 lb.	9.6 oz.	6.1 oz.
144	4	4.5 lb.	4.9 lb.	1.2 lb.	12.7 oz.
182	5	7.8 lb.	8.3 lb.	---	---
277	6	10.4 lb.	11.7 lb.	1.8 lb.	1.2 lb.
470	8	21.2 lb.	26.4 lb.	---	---
810	10	36 lb.	42 lb.	---	---
1320	12	54 lb.	70 lb.	---	---
1650	14	74 lb.	93 lb.	---	---
2230	16	105 lb.	130 lb.	---	---
3010	18	157 lb.	201 lb.	---	---
4000	20	207 lb.	262 lb.	---	---

C<sub>v</sub> values assume Schedule 40 pipe  
See page 46 for Flow Formulae

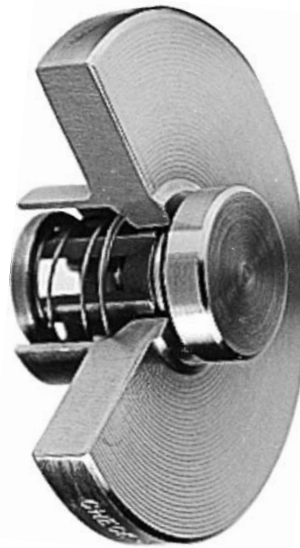
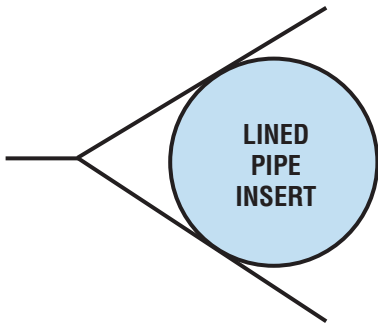

The **Lined Pipe Insert** valve is designed to mate between two flanges on most lined pipe systems. It provides the simplest most economical way to install a check valve in a lined piping system. No gaskets are required, just spread the flanges, center the valve and bolt the flanges together. Lined Pipe Insert valves are available in fluoropolymer (PTFE/FEP/PFA) and *Hastelloy*<sup>®</sup> C Alloy to satisfy the most demanding applications. The standard spring material is *Hastelloy*<sup>®</sup> C Alloy. Other materials are available upon request.

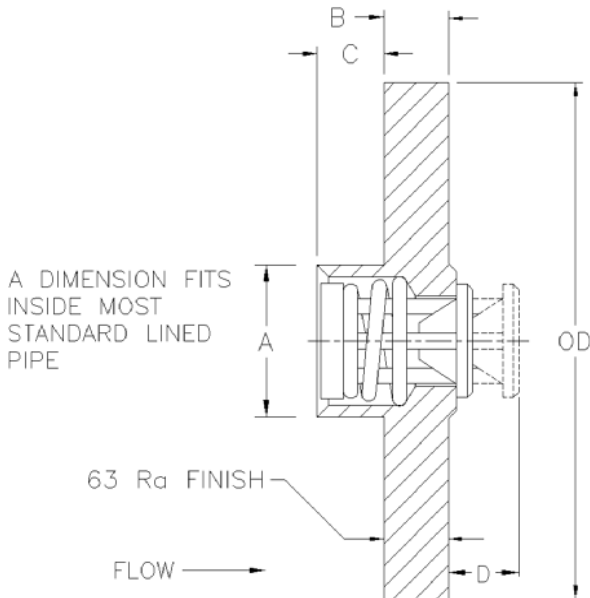

Nom. Pipe Size	Size Code	A	B	C		D <sup>①</sup>	OD	Orifice <sup>②</sup> Diameter
				PTFE	HC			
1	H	0.590	1/4	0.26	0.26	0.53	2	0.348
1-1/2	J	1.120	1/4	0.46	0.42	0.78	2-7/8	0.593
2	K	1.570	1/4	0.55	0.44	1.01	3-5/8	1.135
3	M	2.520	5/16	0.78	0.66	1.43	5	1.555 <sup>③</sup>

<sup>①</sup>Maximum nominal dimension for a fully open valve with no spring.

<sup>②</sup>Orifice Diameter for PTFE valve may vary due to molding process.

<sup>③</sup>3" PTFE valves use 1.385 Orifice Diameter.

Body Material <sup>④</sup>	Nominal Pipe Size	Non-Shock Pressure Rating
<i>Hastelloy</i> <sup>®</sup> C (HC)	1 - 3	ANSI Class 150 & 300
PTFE (TF)	1 - 2	55 PSIG @ 100°F <sup>⑤</sup>
	3	20 PSIG @ 100°F <sup>⑤</sup>

<sup>④</sup>See page 51 for material grade information. Contact the factory for availability of other materials.

<sup>⑤</sup>Consult the factory for reduced P-T rating above 100°F.

**Lined Pipe Insert**  
For Water at 72°F

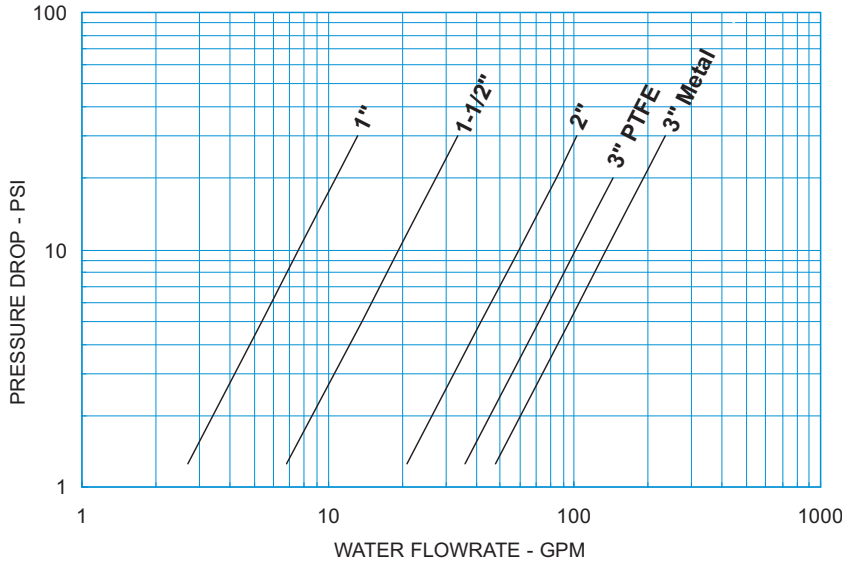

**Note:** All flow curves and Cv values presume the valves are fully open with 1/2 PSI cracking pressure springs. Consult the factory for more information.

STYLE LPI (LP) C <sub>v</sub> VALUES & VALVE WEIGHTS				
METAL C <sub>v</sub>	PTFE C <sub>v</sub>	SIZE	METAL	PTFE
2.4	2.4	1	4.0 oz.	1.0 oz.
6.1	6.1	1-1/2	8.8 oz.	2.2 oz.
18.8	18.8	2	14.4 oz.	3.2 oz.
42.5	32.0	3	2.3 lb.	9.0 oz.

See page 46 for Flow Formulae

**HOW TO ORDER**  
**CHECK-ALL STYLE LPI (LP)**

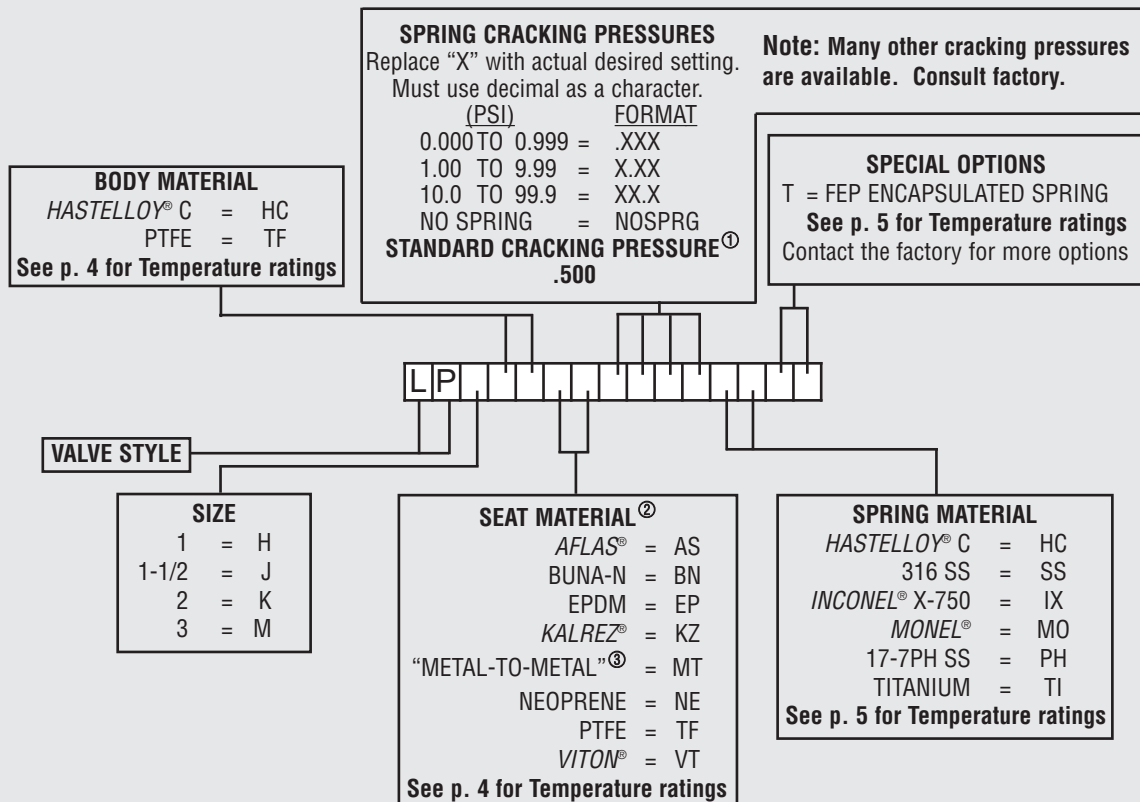

Listed above are the most common material selections. Please contact the factory for additional options.

- ① Cracking pressure tolerance is +/- 15%.
- ② PTFE seats are not resilient. See page 47 for allowable leakage rates.
- ③ For plastic valves, seat is the same as body.

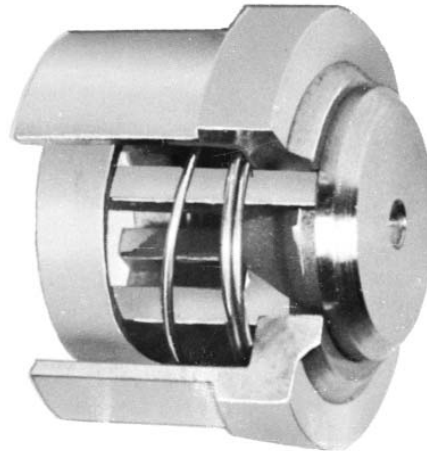
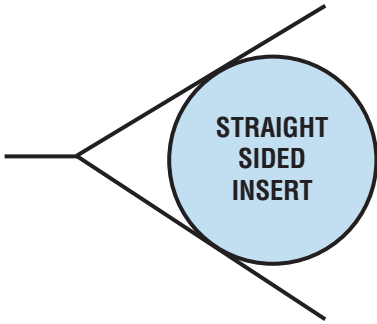

The **Straight Sided Insert** is a **threadless** check valve designed to be inserted into any cavity where a check valve is needed and threads are not desired. Consult the factory if your application requires a press fit installation.

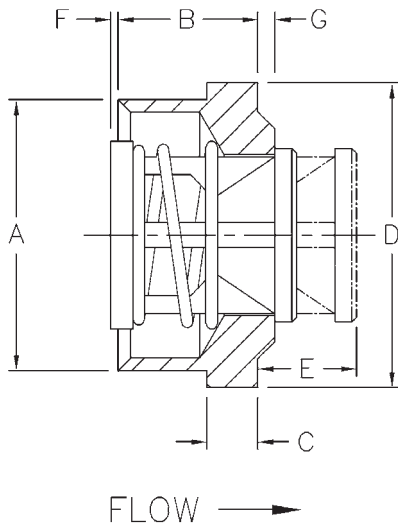

Nom. Pipe Size	Size Code	A	B	C	D	E <sup>①</sup>	F	G	Orifice Diameter
1/2	D	0.656	0.56	0.16	0.718	0.53	0.01	0.031	0.348
3/4	F	0.780	0.59	0.16	0.900	0.61	0	0.063	0.464
1	H	1.000	0.69	0.19	1.125	0.78	0.11	0.063	0.593
1-1/4	I	1.312	0.81	0.19	1.500	0.85	0.09	0.063	0.890
1-1/2	J	1.625	0.88	0.25	1.781	1.01	0.15	0.063	1.135
2	K	1.875	0.88	0.25	2.187	1.19	0.7	0.063	1.385

① Maximum nominal dimension for a fully open valve with no spring.

Body Material <sup>②</sup>	Availability	Non-Shock Pressure-Rating
316 Stainless Steel (SS)	Standard	3000 PSIG @ 100°F (1500 PSIG for o-ring seats)
Carbon Steel (CS)		
Brass (BR)		
ALLOY 20 (A2)	Semi-standard	
Hastelloy® C (HC)		
Monel® (MO)		
Hastelloy® B (HB)	Contact the factory for availability of these or other materials.	
Titanium (TI)		

② See page 51 for material grade information.

**Note:** All flow curves and Cv values presume the valves are fully open with 1/2 PSI cracking pressure springs. Consult the factory for more information.

**Straight Sided Insert**  
For Water at 72°F

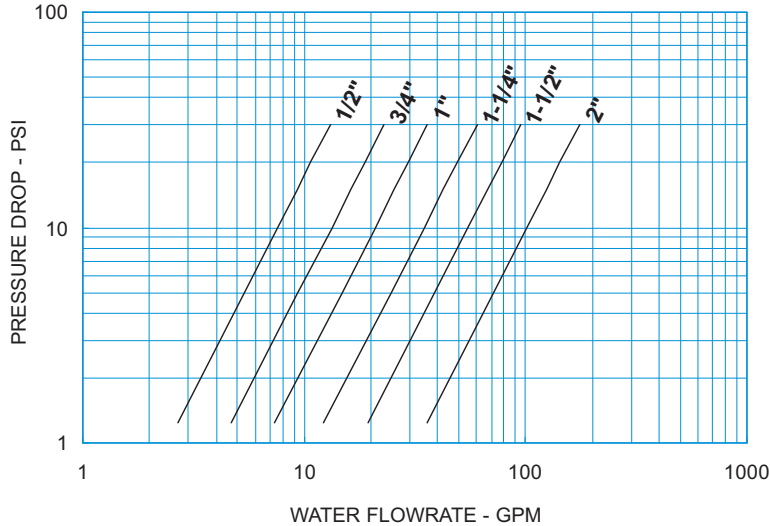

STYLE SSI (SI) C <sub>v</sub> VALUES & VALVE WEIGHTS		
C <sub>v</sub>	SIZE	ALL MATERIALS
2.4	1/2	0.6 oz.
4.2	3/4	1.0 oz.
6.6	1	1.7 oz.
11.0	1-1/4	3.3 oz.
17.4	1-1/2	5.3 oz.
32.0	2	8.2 oz.

See page 46 for Flow Formulae

**HOW TO ORDER  
CHECK-ALL STYLE SSI (SI)**

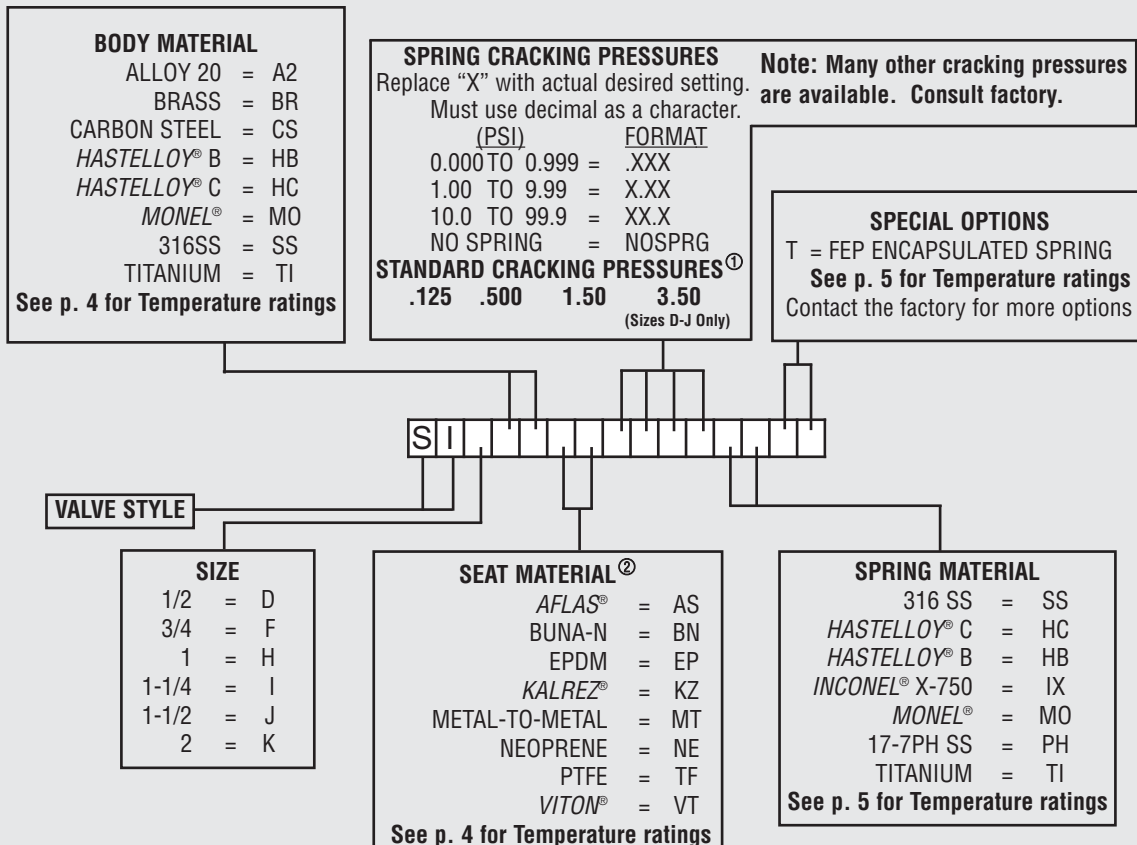

Listed above are the most common material selections. Please contact the factory for additional options.

<sup>①</sup>.500 PSI is the only standard cracking pressure for spring materials other than Stainless Steel. Cracking pressure tolerance is +/- 15%. .125 PSI springs are not recommended for installations with flow vertical down.

<sup>②</sup>Seat materials other than metal-to-metal have a maximum pressure rating of 1500 PSI. PTFE seats are not resilient. See page 47 for allowable leakage rates.



See PED statement below

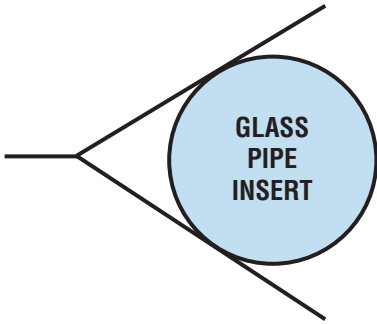

The **Glass Pipe Insert** is an all fluoropolymer (PTFE/FEP/PFA) check valve with a FEP encapsulated spring. The valve is designed to replace the gasket normally used with glass pipe connecting flanges (Flanges not included). It is inserted into one end of the glass pipe and the flange bolts are tightened. No extra pipe or fittings are necessary to install a GPI in the line.

The valve works equally well in any position with proper spring selection, which facilitates installing a check valve anywhere in the system.

**PED Conformance Statement:** Due to the unique design of the Glass Pipe Insert, this series is not considered a pressure vessel but rather a gasket. According to PED Guideline 1/8, gaskets are not governed by the Pressure Equipment Directive. As a result, the GPI series is available for sale in the European Community and no CE Mark is required.

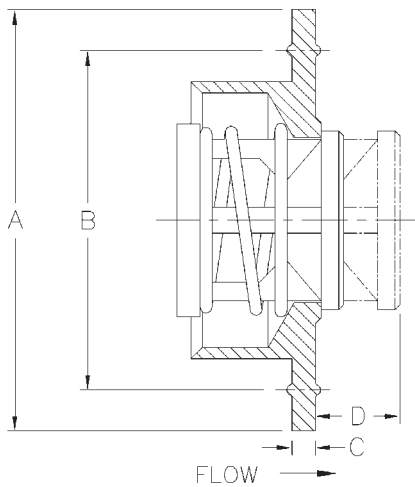

Nom. Pipe Size	Size Code	A	B	C	D <sup>①</sup>	Orifice <sup>②</sup> Diameter
1	H	1-5/8	1.280	0.13	0.73	0.593
1-1/2	J	2-1/4	1.812	0.13	0.86	0.890
2	K	2-3/4	2.312	0.13	0.90	1.135
3	M	3-7/8	3.390	0.14	1.49	2.025
4	N	5-11/32	4.420	0.14	1.90	2.550

<sup>①</sup>Maximum nominal dimension for a fully open valve with no spring.

<sup>②</sup>Due to molding process, orifice may vary.

Body Material <sup>③</sup>	Nominal Pipe Size	Non-Shock Pressure Rating <sup>④</sup>
PTFE (TF)	1 - 2	55 PSIG @ 100°F
	3 - 4	20 PSIG @ 100°F

<sup>③</sup>See page 50 for material grade information.

<sup>④</sup>Consult the factory for reduced P-T rating of PTFE valves above 100°F.





See PED statement below



US Patent Numbers: 5,033,503; 6,039,073; & 6,152,171  
 Canadian Patent Number: 2,039,991

The **3-A SANITARY** valve is an all 316/316L stainless steel check valve with a standard 32 Ra or better finish (finer available) for use in new or existing sanitary systems. This valve's design seals on the ID of sanitary ferrules with 3-A specified materials. The valve seals inside fittings such as Tri-Clover® Bevel Seat and Tri-Clamp®, Waukesha Cherry-Burrell Q-Line® and S-Line®, and others with ID dimensions equal to the "F" dimensions listed below (ferrules not included). This valve is designed to be easily disassembled and spare parts are available. The compact design fits inside a single set of ferrules and requires no additional space in the line. The insert design makes it extremely economical when compared to full-bodied valves. The wide variety of seat materials and cracking pressure springs allow this series to be used as a check valve or vacuum breaker; please specify when ordering.

**PED Conformance Statement:** Due to the unique design of the 3-A Sanitary valve, this series is not considered a pressure vessel but rather a gasket. According to PED Guideline 1/8, gaskets are not governed by the Pressure Equipment Directive. As a result, the 3SC series is available for sale in the European Community and no CE Mark is required.

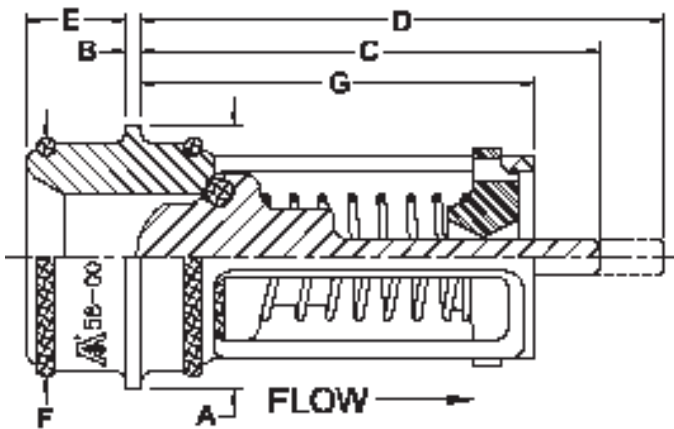

Line Size	Size Code	A	B	C <sup>①</sup>	D <sup>②</sup>	E	F <sup>③</sup>	G	Orifice Diameter
1	H	1	1/16	1.72	2.16	0.38	0.870	1.47	0.476
1-1/2	J	1-1/2	1/16	2.53	3.47	0.38	1.370	2.18	0.890
2	K	2	1/16	3.03	4.13	0.47	1.870	2.59	1.135
2-1/2	L	2-1/2	1/16	3.28	4.59	0.47	2.370	2.85	1.595
3	M	3	1/16	4.59	5.53	0.47	2.870	3.36	2.150
4	N	4	1/16	4.75	6.69	0.47	3.834	4.02	2.699

① Dimension for valve closed.  
 ② Maximum nominal dimension for a fully open valve.  
 ③ Valves are designed to function with fittings having these internal diameters. (±0.005)

Body Material <sup>④</sup>	Line Size	Non-Shock Pressure-Temperature Rating <sup>⑤</sup>
316/316L Stainless Steel (SS)	1	1000 PSIG @ 100°F
	1-1/2 - 4	725 PSIG @ 100°F

④ See page 50 for material grade information.  
 ⑤ Consult the factory for applications where higher pressure or temperature is expected.  
 Note: 30 PSI is the maximum recommended pressure drop.

## Disassembly For Cleaning Instructions

To disassemble the 3-A Sanitary valve, start by depressing one side of the retainer as shown in Step 1. With one side of the retainer tipped, rotate the stem of the poppet and remove the retainer as shown in Steps 2, 3, and 4. To reassemble the valve reverse the process. Consult the factory for information on trim kits, o-ring kits, or individual spare parts.

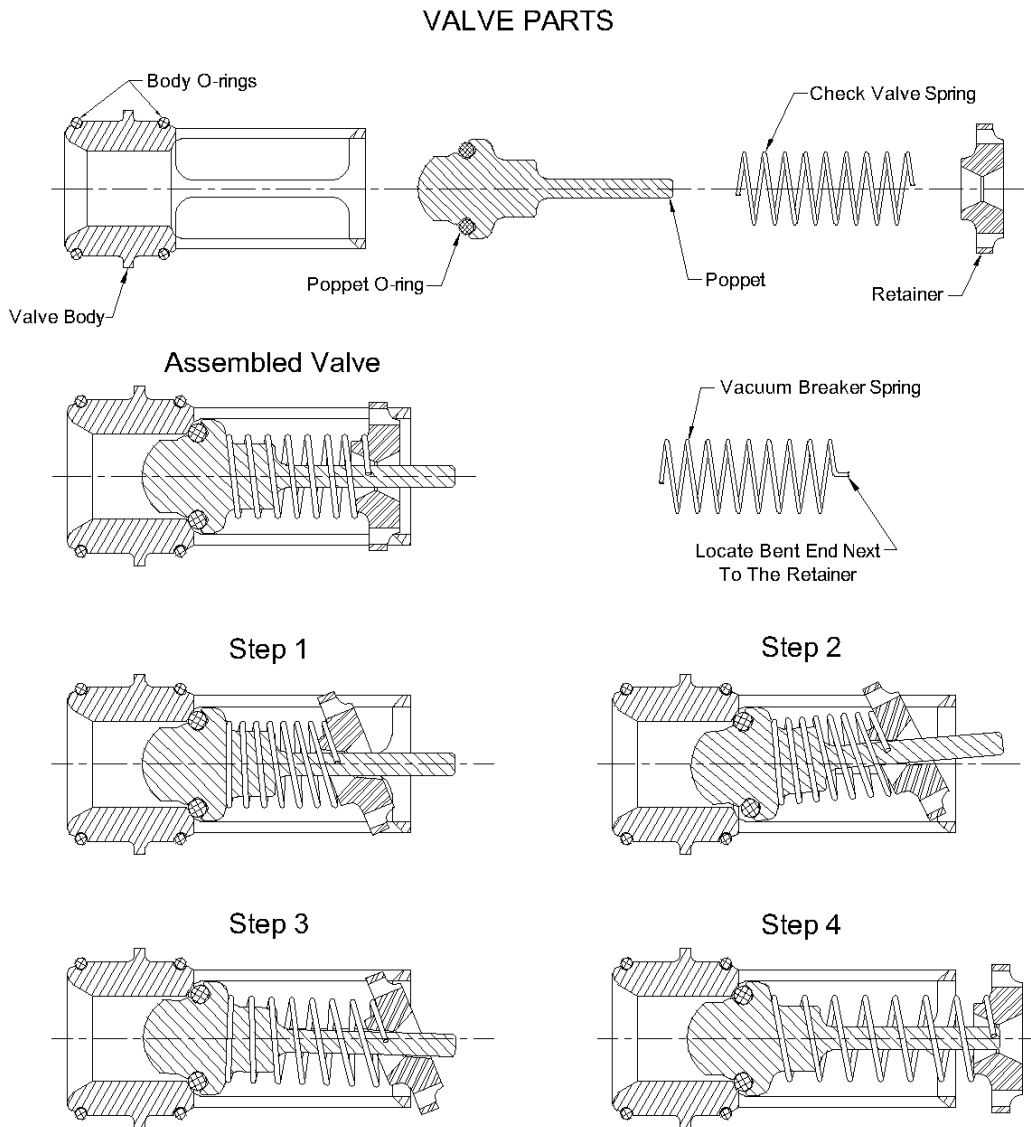

**3-A Sanitary**  
For Water at 72°F

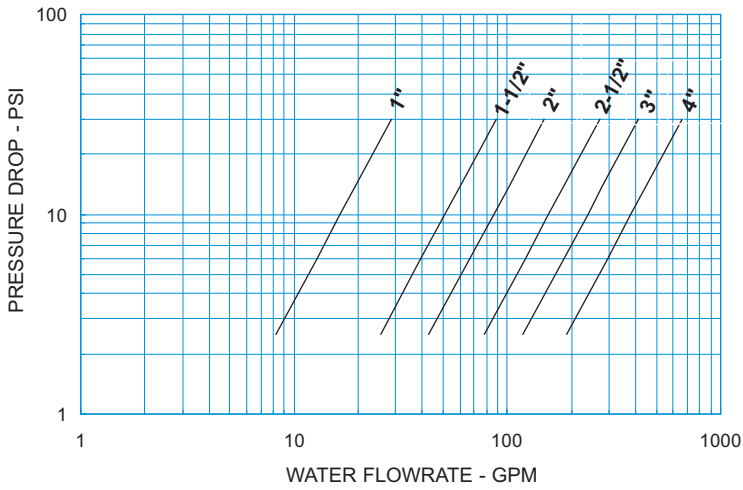

STYLE 3SC (3S) C <sub>v</sub> VALUES & VALVE WEIGHTS		
C <sub>v</sub>	SIZE	316/316L SS
5.2	1	2.3 oz.
16.1	1-1/2	6.2 oz.
27.2	2	13.9 oz.
49.4	2-1/2	1.5 lb.
74.9	3	1.9 lb.
120.0	4	3.9 lb.

See page 46 for Flow Formulae

**Note:** All flow curves and Cv values presume the valves are fully open with 1/2 PSI cracking pressure springs. Consult the factory for more information.

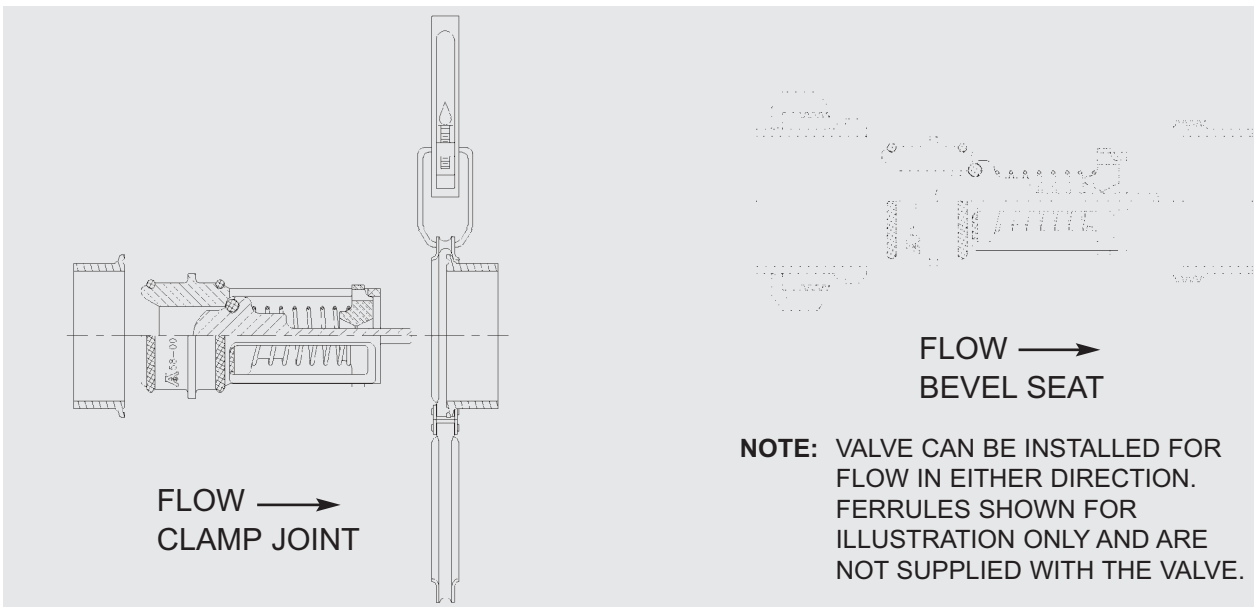

## HOW TO ORDER CHECK-ALL STYLE 3SC (3S)

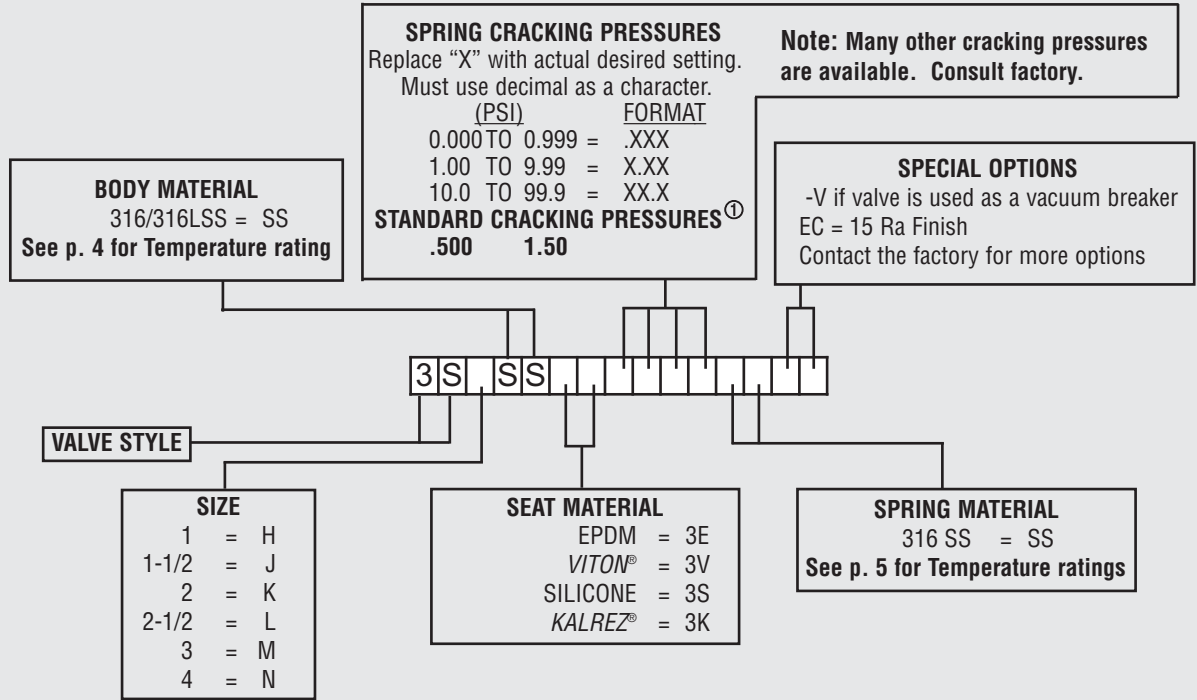

3E - EPDM (-65°F to 300°F)	3K - KALREZ® (0°F to 500°F)
3V - VITON® (-10°F to 400°F)	3S - SILICONE (-80°F to 450°F)
Temperature ranges given are for ideal service conditions and may vary. Consult the factory for assistance with temperature ranges.	

Listed above are the most common material selections. Please contact the factory for additional options.

① Contact factory for non-standard cracking pressure availability. Cracking pressure tolerance is +/- 15%.



See PED statement below

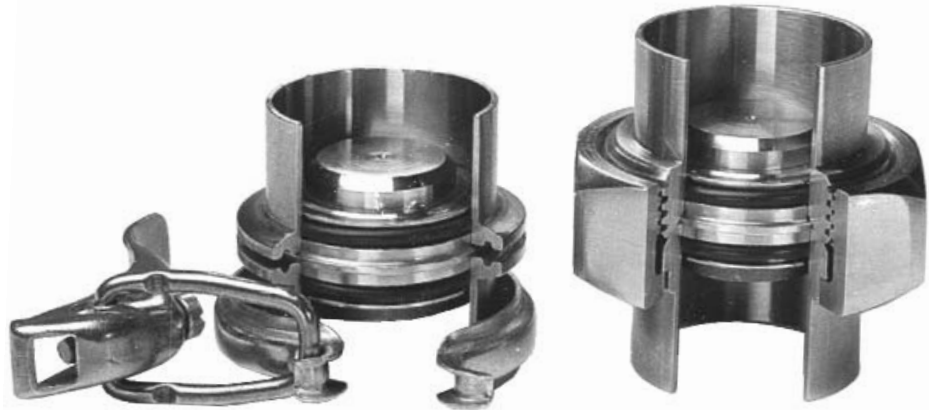
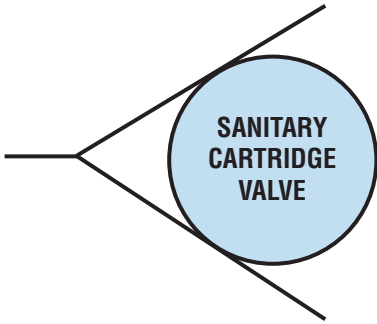

U.S. Patent Number 5,033,503  
Canadian Patent Number 2,039,991

The **Sanitary Cartridge** valve is a 316/316L stainless steel check valve for use in new or existing sanitary systems. The SCV design seals on the ID of sanitary ferrules with replaceable food grade seals (Standard is FDA EPDM). The valve fits the Tri-Clover® Bevel Seat and Tri-Clamp® fittings, the Cherry-Burrell Q-Line® and S-Line® fittings, and others with ID dimensions equal to the “F” dimensions listed below (ferrules not included). The compact SCV design fits inside a single fitting and requires no additional space in the line. Its size makes it extremely economical when compared to full-bodied valves. **For applications requiring a 3-A compliant valve, see our 3S series on page 16.**

Choose from Check-All's broad selection of seat materials and cracking pressure springs that allow this series to be used as a check valve, low pressure relief valve, or as a vacuum breaker.

**PED Conformance Statement:** Due to the unique design of the Sanitary Cartridge Valve, this series is not considered a pressure vessel but rather a gasket. According to PED Guideline 1/8, gaskets are not governed by the Pressure Equipment Directive. As a result, the SCV series is available for sale in the European Community and no CE Mark is required.

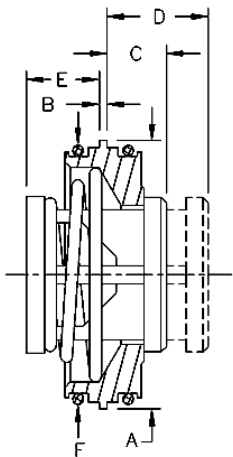

FLOW →

Line Size	Size Code	A	B	C <sup>①</sup>	D <sup>②</sup>	E	F <sup>③</sup>	Orifice Diameter
3/4	F	3/4	1/16	0.44	0.78	0.28	0.620	0.348
1	H	1	1/16	0.53	0.89	0.30	0.870	0.464
1-1/2	J	1-1/2	1/16	0.53	1.06	0.63	1.370	0.890
2	K	2	1/16	0.66	1.39	0.66	1.870	1.135
2-1/2	L	2-1/2	1/16	0.69	1.56	0.88	2.370	1.385
3	M	3	1/16	0.75	1.97	1.25	2.870	2.025
4	N	4	1/16	0.88	2.41	1.63	3.834	2.560

① Dimension for valve closed.

② Maximum nominal dimension for a fully open valve with no spring.

③ Valves are designed to function with fittings having these internal diameters.(±0.005)

Body Material <sup>④</sup>	Line Size	Non-Shock Pressure-Temperature Rating <sup>⑤</sup>
316/316L Stainless Steel (SS)	3/4 - 1-1/2	1000 PSIG @ 100°F
	2 - 4	725 PSIG @ 100°F

④ See page 51 for material grade information.

⑤ Consult the factory for applications where higher pressure or temperature is required.

**Sanitary Cartridge Valve**  
For Water at 72°F

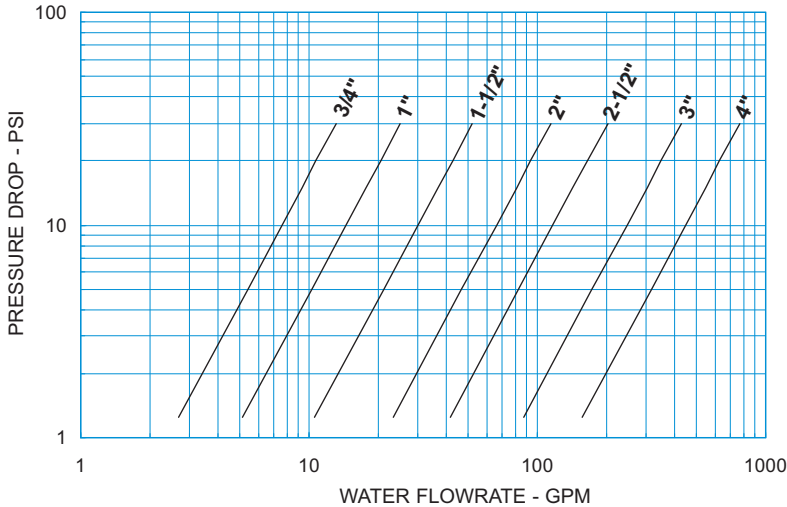

**Note:** All flow curves and Cv values presume the valves are fully open with 1/2 PSI cracking pressure springs. Consult the factory for more information.

STYLE SCV (SC) C <sub>v</sub> VALUES & VALVE WEIGHTS		
C <sub>v</sub>	SIZE	316 SS
2.4	3/4	0.3 oz.
4.6	1	1.0 oz.
9.5	1-1/2	2.9 oz.
20.9	2	6.1 oz.
37.0	2-1/2	11.2 oz.
77.9	3	11.4 oz.
141	4	2.3 lb.

See page 46 for Flow Formulae

**HOW TO ORDER  
CHECK-ALL STYLE SCV (SC)**

**BODY MATERIAL**  
316/316LSS = SS  
See p. 4 for Temperature rating

**SPRING CRACKING PRESSURES**  
Replace "X" with actual desired setting.  
Must use decimal as a character.  
(PSI)                      FORMAT  
0.000 TO 0.999 = .XXX  
1.00 TO 9.99 = X.XX  
10.0 TO 99.9 = XX.X  
NO SPRING = NOSPRG  
**STANDARD CRACKING PRESSURES** ①  
.125 .500 1.50 3.50  
(Sizes F-K Only)

**Note: Many other cracking pressures are available. Consult factory.**

SC	SS								
----	----	--	--	--	--	--	--	--	--

**VALVE STYLE**

SIZE	
3/4	= F
1	= H
1-1/2	= J
2	= K
2-1/2	= L
3	= M
4	= N

**SEAT MATERIAL**

AFLAS® = AS  
BUNA-N = BN  
EPDM = EP  
FDA BUNA = FB  
FDA EPDM = FE  
FDA VITON® = FV  
KALREZ® = KZ  
METAL-TO-METAL = MT  
NEOPRENE = NE  
PTFE = TF  
VITON® = VT

See p. 4 for Temperature ratings

**SPRING MATERIAL**

316 SS = SS  
HASTELLOY® C = HC  
INCONEL® X-750 = IX  
MONEL® = MO  
17-7PH SS = PH  
TITANIUM = TI

See p. 5 for Temperature ratings

Listed above are the most common material selections. Please contact the factory for additional options.

① .500 PSI is the only standard cracking pressure for spring materials other than Stainless Steel. Cracking pressure tolerance is +/- 15%.



See PED statement below

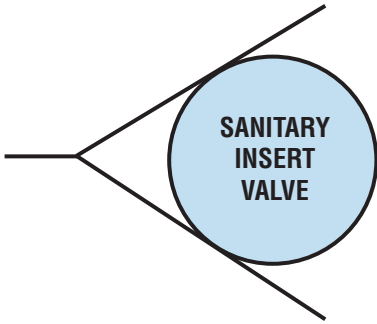

For over 35 years, the compact, fluoropolymer (PTFE/FEP/PFA), **Sanitary Insert** valve has been used as the most economical solution for providing a check valve in a new or existing sanitary piping system. This valve style is designed to fit into grooved-end clamp-type fittings (ferrules not included). Since the Sanitary Insert Valve replaces the gasket normally used with clamp joints, no extra space is required to accommodate the valve. **For applications requiring a 3-A compliant valve, see our 3S series on page 16.**

**PED Conformance Statement:** Due to the unique design of the Sanitary Insert Valve, this series is not considered a pressure vessel but rather a gasket. According to PED Guideline 1/8, gaskets are not governed by the Pressure Equipment Directive. As a result, the SIV series is available for sale in the European Community and no CE Mark is required.

Two different types of Sanitary Insert Valves are available. They are distinguished by the following designations in their part numbers:

TC – Designates the Tri-Clamp® fittings manufactured by Tri-Clover®,      CB – Designates the Q-Line® Series of fittings manufactured by Waukesha Cherry-Burrell.  
 S-Line® fittings manufactured by Waukesha Cherry-Burrell.

NOTE: Sanitary Insert Valve types TC and CB are not interchangeable!

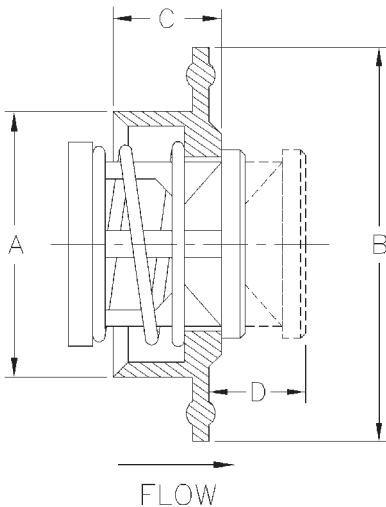

Line Size	Size Code	TC - Tri-Clover® Waukesha Cherry-Burrell S-Line®				CB - Waukesha Cherry-Burrell Q-Line® Only				Orifice ① Dia.
		A	B	C	D ②	A	B	C	D ②	
3/4	F	0.585	27/32	0.55	0.61	-	-	-	-	0.348
1	H	0.850	2	0.55	0.69	0.850	1-3/4	0.55	0.69	0.464
1-1/2	J	1.340	2	0.55	0.91	1.350	2	0.55	0.91	0.890
2	K	1.840	2-1/2	0.57	1.11	1.850	2-1/2	0.57	0.98	1.135
2-1/2	L	2.350	3	0.60	0.97	2.250	3-1/4	0.60	0.97	1.385
3	M	2.840	3-1/2	0.64	1.58	2.852	3-55/64	0.61	1.58	2.025
4	N	3.801	4-5/8	0.78	1.89	3.800	4-55/64	0.73	1.89	2.560

① Due to molding process, orifice may vary.  
 ② Maximum nominal dimension for a fully open valve with no spring.

Body Material ③	Line Size	Non-Shock Pressure-Temperature Rating ④
PTFE (TF)	3/4 - 2	55 PSIG @ 100°F
	2-1/2 - 4	20 PSIG @ 100°F

③ See page 51 for material grade information.

④ Consult the factory for reduced P-T rating of PTFE valves above 100°F.





See PED statement below

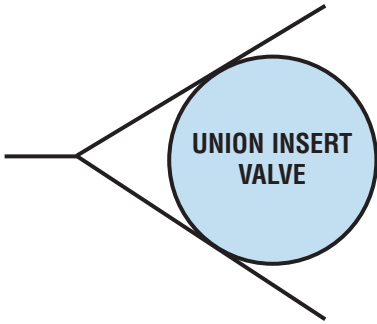

The **Union Insert** valve is the threaded pipe counterpart of the Flange Insert Valve. Designed to be inserted into most standard ground joint unions, it provides the simplest and most economical way to install a check valve in a threaded pipe system. A check valve may be installed anywhere in the system where there is a union. The valve works equally well in either a horizontal or vertical position with proper spring selection. Each Union Insert valve is furnished with a **metal tag**, which is quickly attached to the union. The tag is attached when the valve is installed and provides a **permanent record** that the union contains a check valve.

**NOTE:** Bore of union must be equal to I.D. of schedule 40 pipe. Use ground joint unions with 45° seat only (union not included).

**PED Conformance Statement:** Due to the unique design of the Union Insert Valve, this series is not considered a pressure vessel but rather a gasket. According to PED Guideline 1/8, gaskets are not governed by the Pressure Equipment Directive. As a result, the UIV series is available for sale in the European Community and no CE Mark is required.

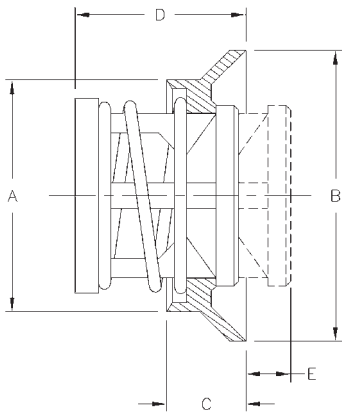

FLOW →

Nom. Pipe Size	Size Code	A	B	C	D	E ①	Orifice Diameter
1/2	D	0.625	0.938	0.42	0.74	0.55	0.348
3/4	F	0.812	1.125	0.42	0.77	0.45	0.464
1	H	1.032	1.437	0.45	1.04	0.58	0.593
1-1/4	I	1.360	1.750	0.51	1.14	0.67	0.890
1-1/2	J	1.593	2.000	0.54	1.27	0.84	1.135
2	K	2.000	2.500	0.61	1.54	0.94	1.385

① Maximum nominal dimension for a fully open valve with no spring.

Body Material ②	Availability	Non-Shock Pressure-Temperature Rating
316 Stainless Steel (SS)	Standard	3000 PSIG @ 100°F (1500 PSIG for o-ring seats)
Carbon Steel (CS)		
Brass (BR)		
Alloy 20 (A2)	Semi-standard	
Hastelloy® C (HC)		
Mone® (MO)		
Hastelloy® B (HB)	Contact the factory for these or other materials	
Titanium (TI)		

② See page 51 for material grade information.

**Union Insert Valve**  
For Water at 72°F

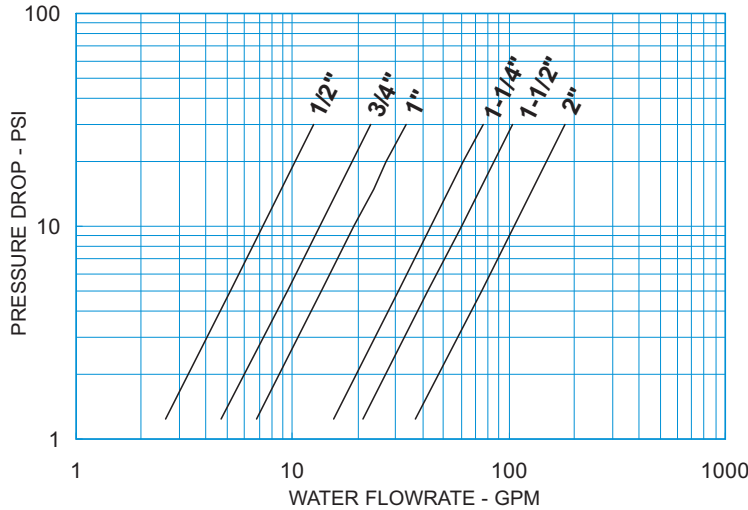

**Note:** All flow curves and Cv values presume the valves are fully open with 1/2 PSI cracking pressure springs. Consult the factory for more information.

STYLE UIV (UV) C <sub>v</sub> VALUES & VALVE WEIGHTS		
C <sub>v</sub>	SIZE	ALL MATL
2.3	1/2	0.5 oz.
4.2	3/4	0.8 oz.
6.1	1	1.6 oz.
13.8	1-1/4	2.8 oz.
19.0	1-1/2	4.3 oz.
33.3	2	7.8 oz.

See page 46 for Flow Formulae

**HOW TO ORDER  
CHECK-ALL STYLE UIV (UV)**

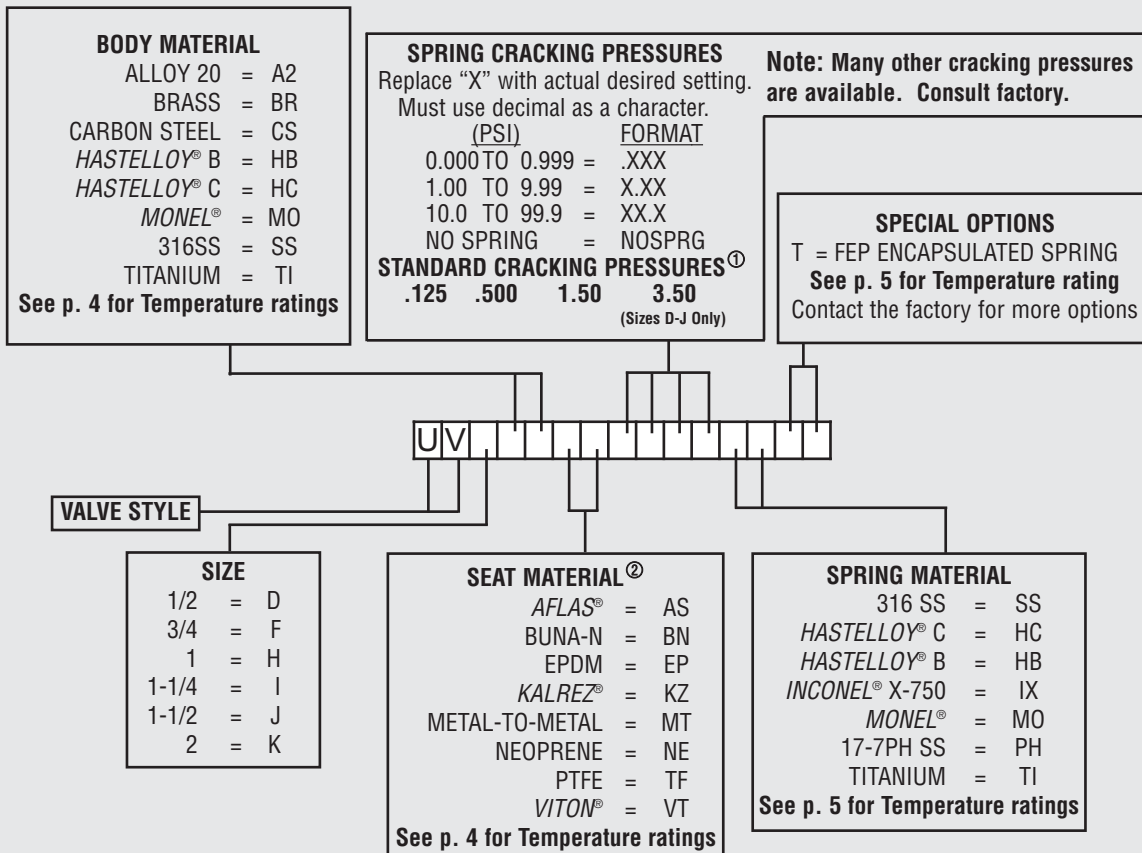

Listed above are the most common material selections. Please contact the factory for additional options.

① .500 PSI is the only standard cracking pressure for spring materials other than Stainless Steel. Cracking pressure tolerance is +/- 15%. .125 PSI springs are not recommended for installations with flow vertical down.

② Seat materials other than metal-to-metal have a maximum pressure rating of 1500 PSI. PTFE seats are not resilient. See page 47 for allowable leakage rates.

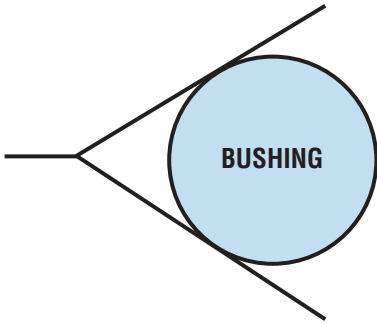

The **Bushing** valve is a check valve with a standard bushing housing. The valve is adaptable to many types of service applications. It has very little restriction and produces a low pressure drop. It can be used quite effectively in systems where flow and pressure drop are critical by the use of a reducer coupling. The Bushing valve also makes an excellent **vacuum breaker**. The high flow rate insures maximum effectiveness for vacuum breaker service. By reversing the direction of flow it can also be used as a low-pressure **relief valve**.

The bushing thread sizes are designated by two sets of numbers; the first being the male thread, the second the female thread.

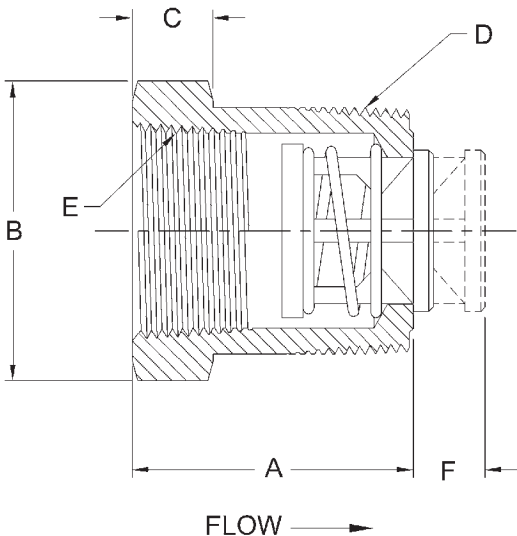

Nom. Pipe Size	Size Code	A	Hex <sup>①</sup> Size B	C	D	E	F <sup>②</sup>	Orifice Dia.
1/2 x 3/8	D	1.30	7/8	1/4	1/2 NPT	3/8 NPT	0.53	0.348
3/4 x 1/2	F	1.30	1-1/8	1/4	3/4 NPT	1/2 NPT	0.61	0.464
1 x 3/4	H	1.83	1-3/8	1/2	1 NPT	3/4 NPT	0.78	0.593
1-1/4 x 1	I	1.83	1-3/4	1/2	1-1/4 NPT	1 NPT	0.85	0.890
1-1/2 x 1-1/4	J	2.17	2	5/8	1-1/2 NPT	1-1/4 NPT	1.01	1.135
2 x 1-1/2	K	2.17	2-1/2	5/8	2 NPT	1-1/2 NPT	1.19	1.385
2-1/2 x 2	L	2.53	3	5/8	2-1/2 NPT	2 NPT	1.43	1.555
3 x 2-1/2	M	3.09	3-1/2	1	3 NPT	2-1/2 NPT	1.59	2.025

<sup>①</sup> May be larger and/or round.

<sup>②</sup> Maximum nominal dimension for a fully open valve with no spring.

Body Material <sup>③</sup>	Availability	Non-Shock Pressure-Temperature Rating
316 Stainless Steel (SS)	Standard	3000 PSIG @ 100°F (1500 PSIG for o-ring seats)
Carbon Steel (CS)		
Brass (BR)		
Alloy 20 (A2)	Semi-standard	
Hastelloy® C (HC)		
Mone® (MO)		
Hastelloy® B (HB)	Contact the factory for these or other materials	
Titanium (TI)		

<sup>③</sup> See page 51 for material grade information.

**Bushing**  
For Water at 72°F

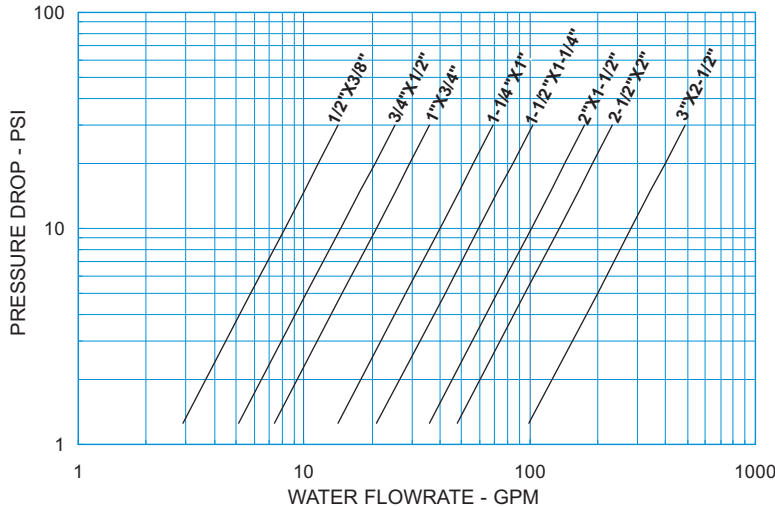

**Note:** All flow curves and Cv values presume the valves are fully open with 1/2 PSI cracking pressure springs. Consult the factory for more information.

STYLE BU C <sub>v</sub> VALUES & VALVE WEIGHTS		
C <sub>v</sub>	SIZE	ALL MATL
2.6	1/2 x 3/8	1.7 oz.
4.6	3/4 x 1/2	2.9 oz.
6.6	1 x 3/4	6.4 oz.
12.6	1-1/4 x 1	10.8 oz.
18.8	1-1/2 x 1-1/4	13.8 oz.
32.0	2 x 1-1/2	1.6 lb.
42.5	2-1/2 x 2	2.3 lb.
89.0	3 x 2-1/2	5.4 lb.

See page 46 for Flow Formulae

**HOW TO ORDER  
CHECK-ALL STYLE BU**

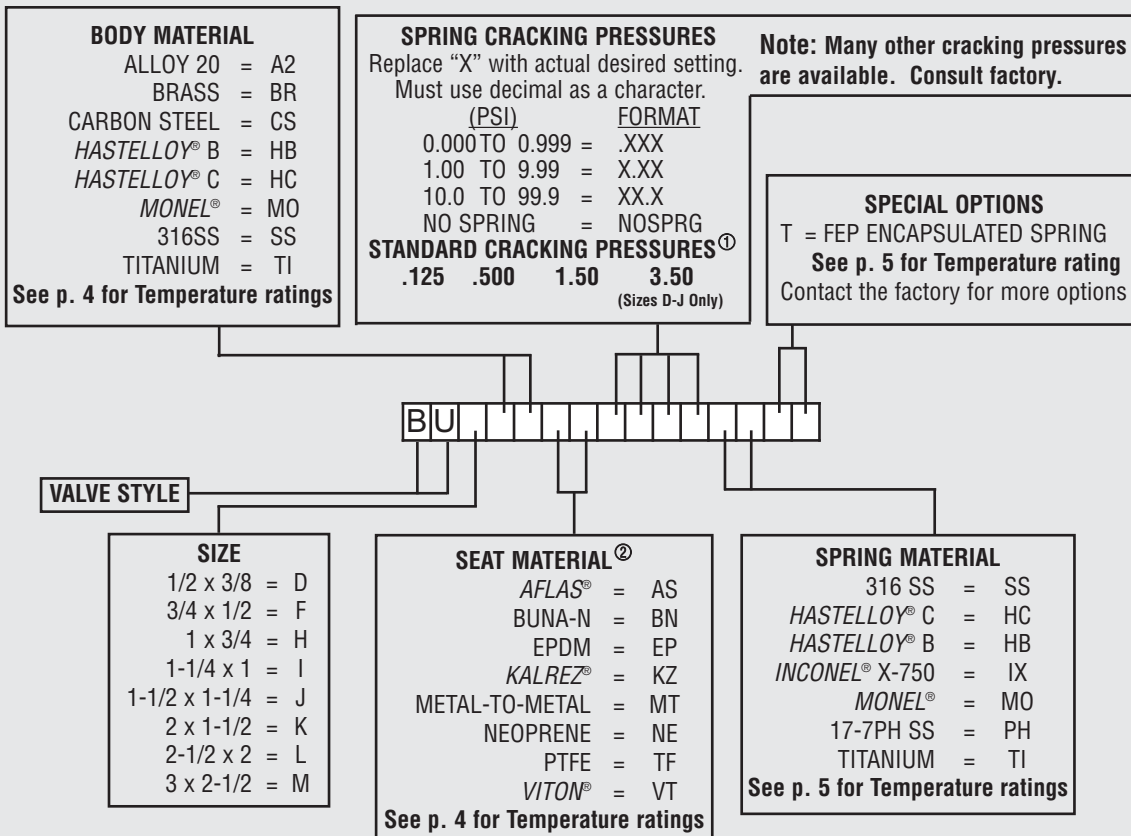

Listed above are the most common material selections. Please contact the factory for additional options.

① .500 PSI is the only standard cracking pressure for spring materials other than Stainless Steel. Cracking pressure tolerance is +/- 15%. .125 PSI springs are not recommended for installations with flow vertical down.

② Seat materials other than metal-to-metal have a maximum pressure rating of 1500 PSI. PTFE seats are not resilient. See page 47 for allowable leakage rates.

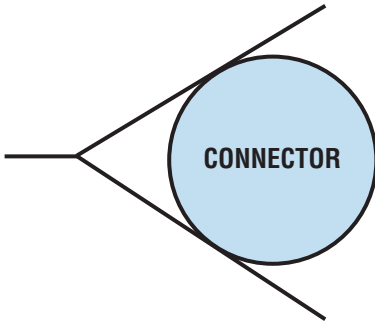

The **Connector** valve is a check valve with a hex nipple or connector housing. It is designed to be used in installations where a check valve with male pipe threads are required. The Connector valve is adaptable for use as a check valve, vacuum breaker, or low pressure relief valve. Two valves used in combination make an excellent low pressure relief/vacuum breaker. Also available with ISO 7 "R" threads.

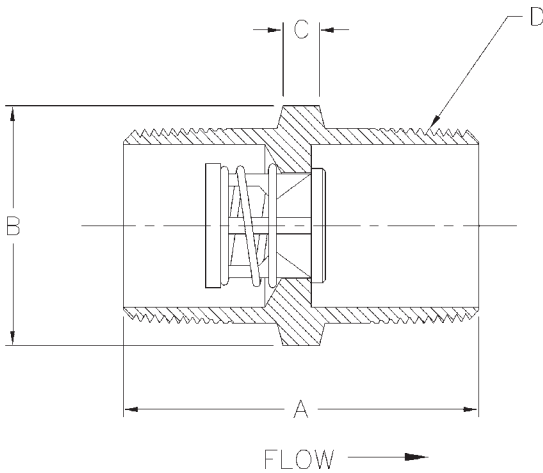

Nom. Pipe Size	Size Code	A	Hex <sup>①</sup> Size B	C	D	Orifice Diameter
1/2	D	2.34	7/8	0.28	1/2 NPT	0.348
3/4	F	2.34	1-1/8	0.27	3/4 NPT	0.464
1	H	3.00	1-3/8	0.35	1 NPT	0.593
1-1/4	I	3.00	1-3/4	0.33	1-1/4 NPT	0.890
1-1/2	J	3.19	2	0.32	1-1/2 NPT	1.135
2	K	3.68	2-1/2	0.38	2 NPT	1.385
2-1/2	L	5.00	3-1/4	N/A	2-1/2 NPT	1.555
3	M	5.50	4	N/A	3 NPT	2.025
4	N	5.00	5	0.61	4 NPT	2.560

<sup>①</sup>May be larger and/or round.

Body Material <sup>②</sup>	Availability	Non-Shock Pressure-Temperature Rating	
316 Stainless Steel (SS)	Standard	1/2" - 3" 3000 PSIG @ 100°F (1500 PSIG for o-ring seats)	4" 1500 PSIG @ 100°F
Carbon Steel (CS)			
Brass (BR)			
Alloy 20 (A2)	Semi-standard		
Hastelloy <sup>®</sup> C (HC)			
Mone <sup>®</sup> (MO)			
Hastelloy <sup>®</sup> B (HB)			
Titanium (TI)	Contact the factory for availability of these or other materials		

<sup>②</sup>See page 50 for material grade information.

**Note:** All flow curves and Cv values presume the valves are fully open with 1/2 PSI cracking pressure springs. Consult the factory for more information.

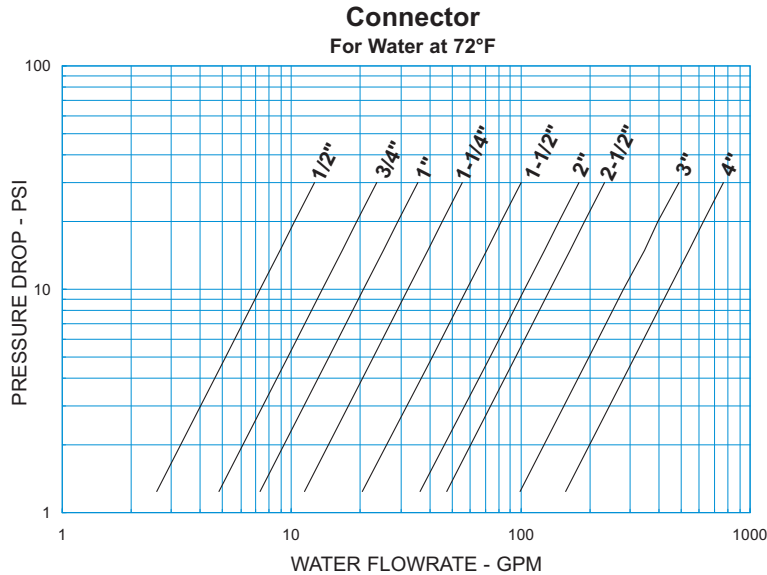

STYLE CON (CN) C <sub>v</sub> VALUES & VALVE WEIGHTS		
C <sub>v</sub>	SIZE	ALL MATL
2.3	1/2	2.5 oz.
4.3	3/4	3.9 oz.
6.5	1	7.5 oz.
10.2	1-1/4	10.9 oz.
18.3	1-1/2	1.5 lb.
32.7	2	2.7 lb.
42.5	2-1/2	5.0 lb.
89.0	3	8.9 lb.
140	4	10.3 lb.

See page 46 for Flow Formulae

## HOW TO ORDER CHECK-ALL STYLE CON (CN)

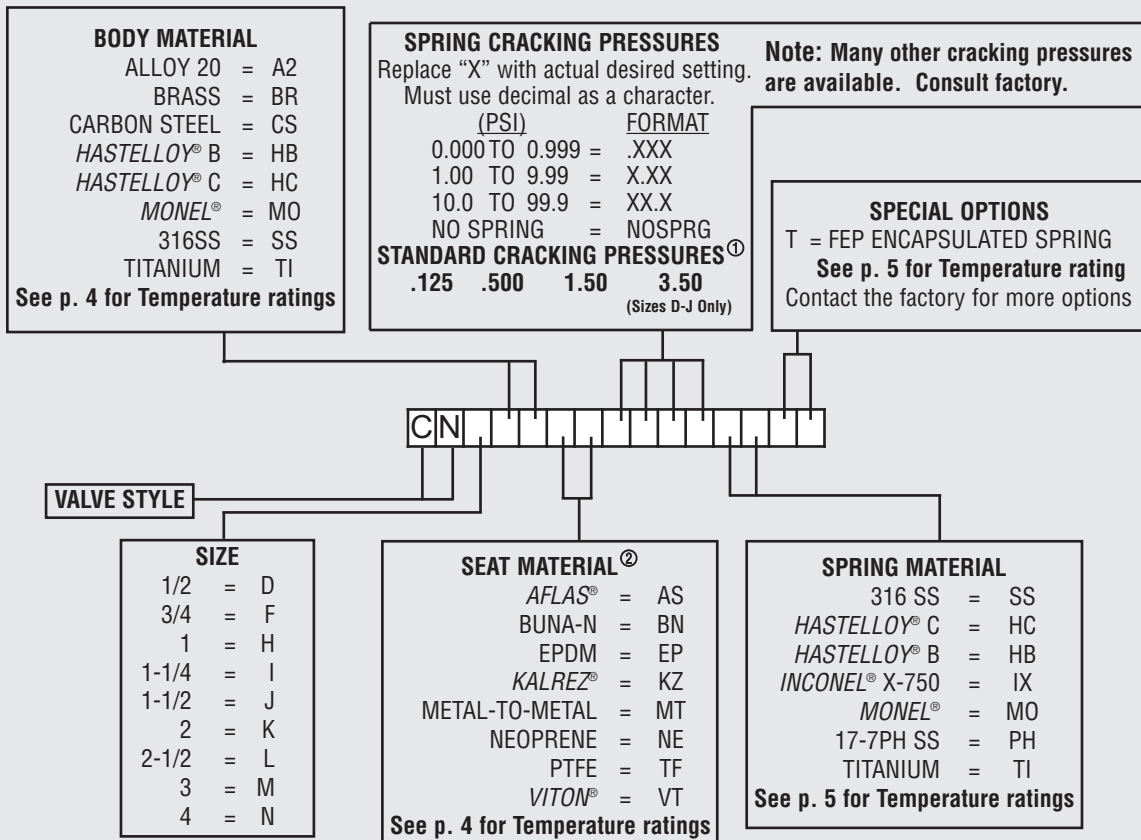

Listed above are the most common material selections. Please contact the factory for additional options.

① .500 PSI is the only standard cracking pressure for spring materials other than Stainless Steel. Cracking pressure tolerance is +/- 15%. .125 PSI springs are not recommended for installations with flow vertical down.

② Seat materials other than metal-to-metal have a maximum pressure rating of 1500 PSI. PTFE seats are not resilient. See page 47 for allowable leakage rates.

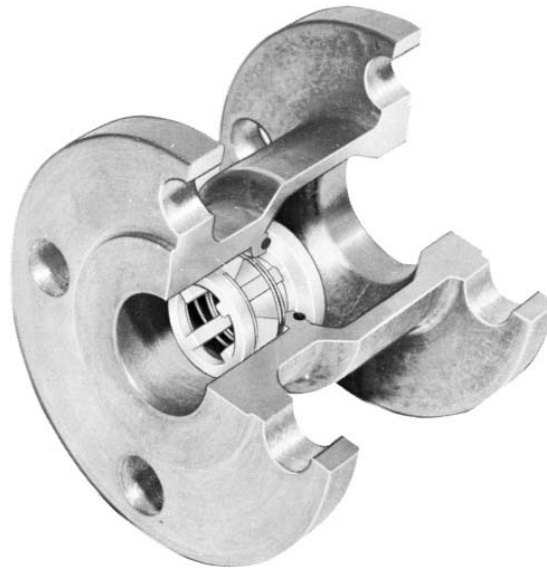
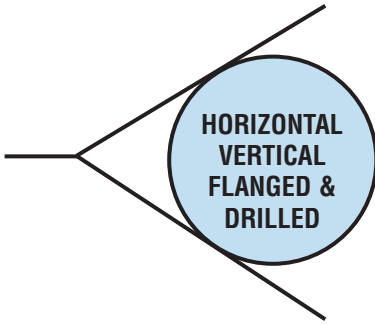

The **Check-All Flanged & Drilled** check valve is a one piece cast body valve with ANSI/ASME B16.5 Class 150 flanged ends. The HVFD series valve is used when higher flow rates and lower pressure drops are required. The valve is available in sizes 1 through 10 inches and standard materials of 316 stainless steel, brass and carbon steel. The HVFD series valve is designed for use with mating ANSI class 150 flanges. Other materials are available upon request.

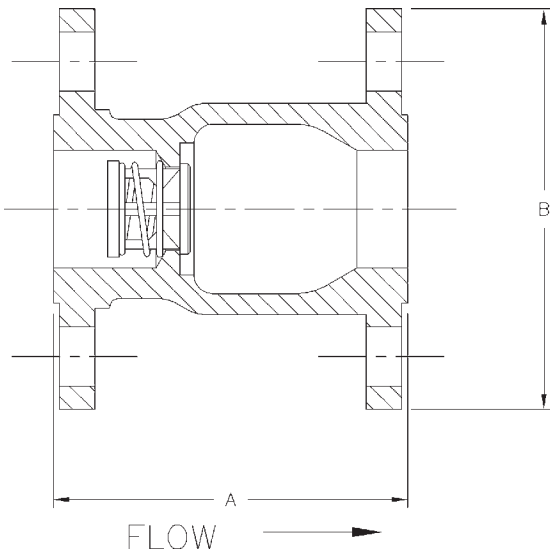

Nom. Pipe Size	Size Code	A	B	Orifice Diameter
1	H	3.75	4-1/4	0.890
1-1/2	J	4.38	5	1.385
2	K	5.13	6	2.025
2-1/2	L	7.28	7	2.560
3	M	8.38	7-1/2	3.280
4	N	9.69	9	3.875
6	P	13.75	11	6.380
8	Q	15.10	13-1/2	7.670
10	R	19.25	16	9.650

Body Material <sup>①</sup>	Availability	Non-Shock Pressure-Temperature Rating
316 Stainless Steel (SS)	Standard	ANSI/ASME B16.5 Class 150
Carbon Steel (CS)		
Brass (BR)		

<sup>①</sup>See page 50 for material grade information.

**Note:** All flow curves and Cv values presume the valves are fully open with 1/2 PSI cracking pressure springs. Consult the factory for more information.

**Horizontal Vertical Flanged & Drilled**  
For Water at 72°F

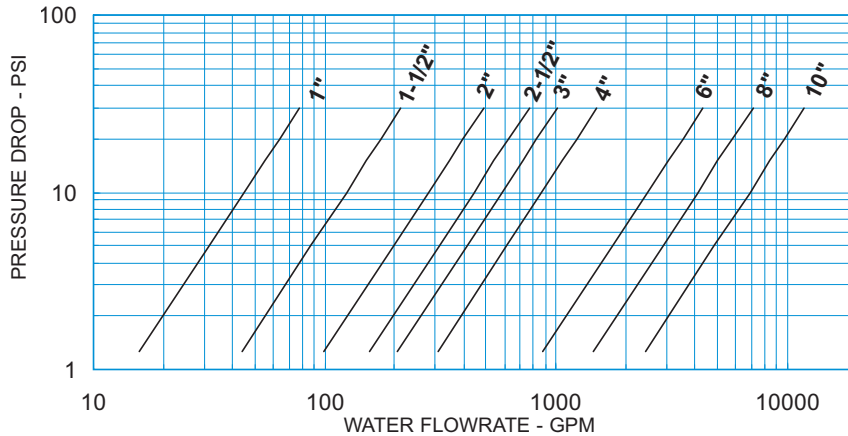

STYLE HVFD (HV) C <sub>v</sub> VALUES & VALVE WEIGHTS			
C <sub>v</sub>	SIZE	SS & CS	BRASS
14.2	1	4.4 lb.	4.5 lb.
39.2	1-1/2	7.7 lb.	6.7 lb.
89.0	2	10.9 lb.	13.9 lb.
140	2-1/2	20.7 lb.	23 lb.
185	3	24.6 lb.	26.2 lb.
275	4	43.8 lb.	48 lb.
790	6	86 lb.	93 lb.
1300	8	174 lb.	193 lb.
2175	10	263 lb.	290 lb.

See page 46 for Flow Formulae

**HOW TO ORDER  
CHECK-ALL STYLE HVFD (HV)**

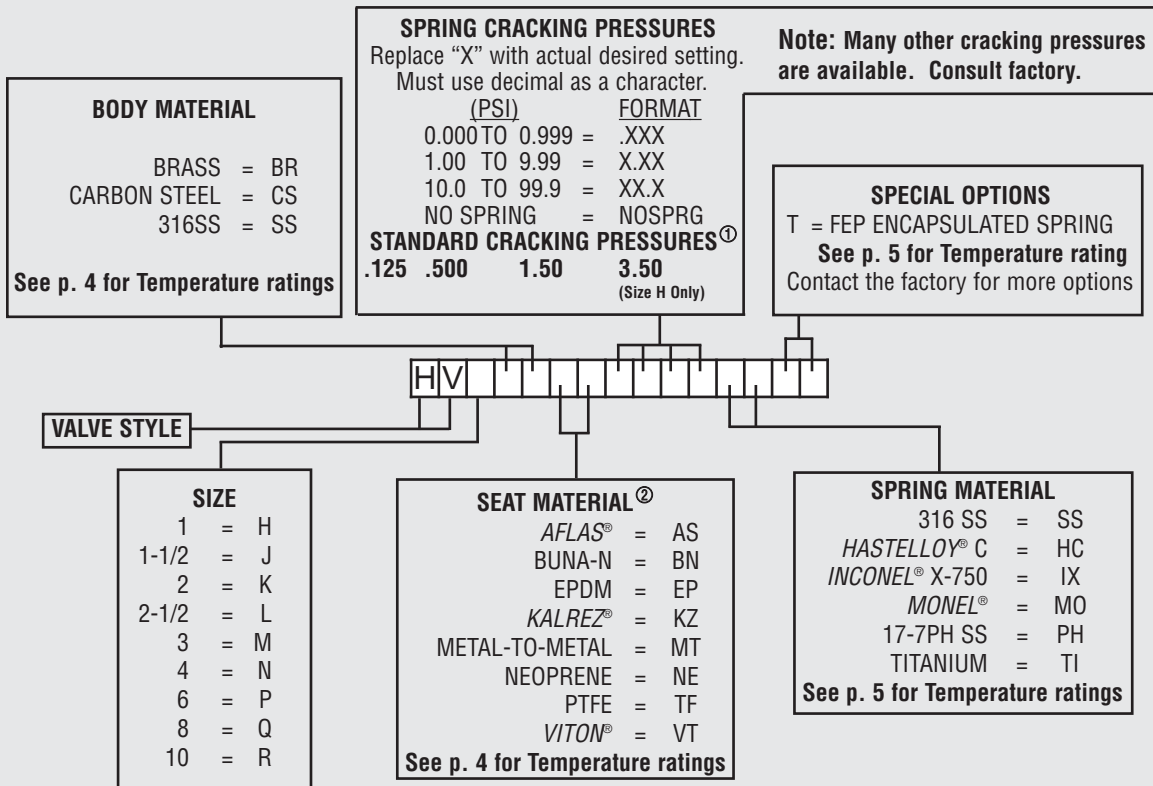

Listed above are the most common material selections. Please contact the factory for additional options.

① .500 PSI is the only standard cracking pressure for spring materials other than Stainless Steel. Cracking pressure tolerance is +/- 15%. .125 PSI springs are not recommended for installations with flow vertical down.

② Seat materials other than metal-to-metal have a maximum pressure rating of 1500 PSI. PTFE seats are not resilient. See page 47 for allowable leakage rates.



PED 97/23/EC  
COMPLIANT  
See Page 52 for Details

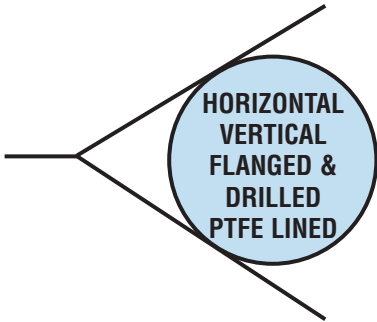

The **Check-All Flanged & Drilled — Fluoropolymer (PTFE) Lined** check valve is a one piece body with ANSI/ASME B16.5 Class 150 flanged ends. The valve has a solid one piece PTFE liner which covers the flange faces out to the raised face diameter. All wetted surfaces are fluoropolymer (PTFE/FEP/PFA) including the FEP encapsulated stainless steel spring.

Style HVFD-T bodies are made of **cast carbon steel only**. The liner is made of virgin PTFE. It is installed as one solid piece of PTFE and the internal geometrical shape is machined. The PTFE liner has a **minimum wall** thickness of 3/32 inch, which guarantees against pin holes which can be present in fused liners.

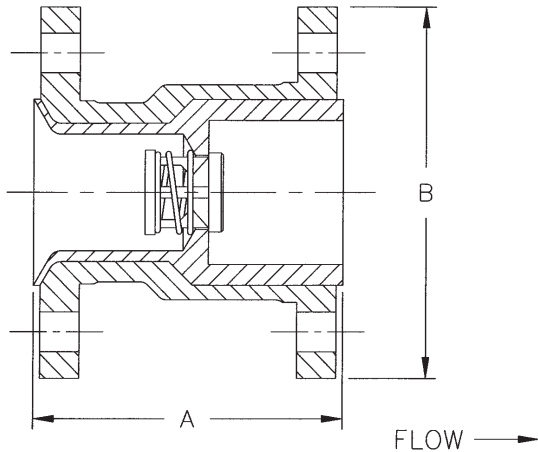

Nom. Pipe Size	Size Code	A	B	Orifice <sup>①</sup> Diameter
1	H	3.75	4-1/4	0.890
1-1/2	J	4.38	5	1.385
2	K	5.13	6	2.025

<sup>①</sup>Due to molding process, orifice may vary.

Body Material <sup>②</sup>	Liner Material <sup>②</sup>	Nominal Pipe Size	Non-Shock Pressure-Temperature Rating <sup>③</sup>
Carbon Steel (CS)	PTFE (TF)	1	55 PSIG @ 100°F
		1-1/2 - 2	20 PSIG @ 100°F

<sup>②</sup>See page 51 for material grade information.

<sup>③</sup>Consult the factory for reduced P-T rating of PTFE valves above 100°F.



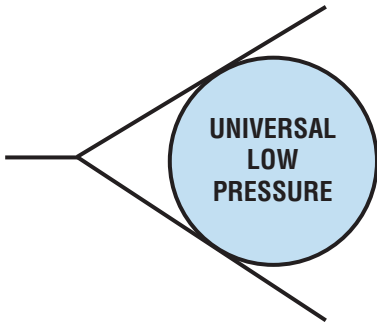

The **Universal Low Pressure** check valve is a one piece body machined from bar stock and is designed for minimum pressure drop. The valve has a light weight compact design that provides maintenance-free dependable service. Also available with ISO 7 “Rp” threads.

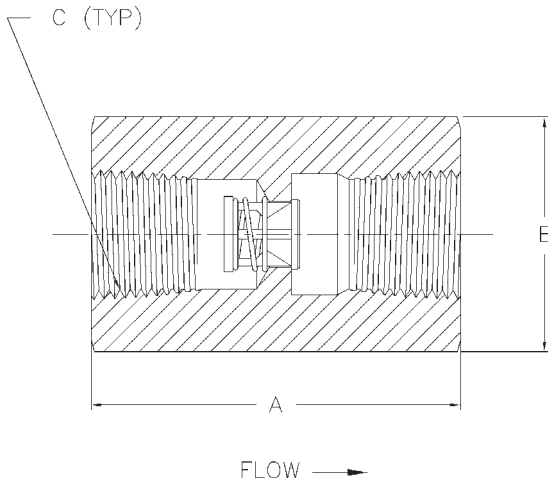

Nom. Pipe Size	Size Code	A	Hex <sup>①</sup> Size B	C <sup>②</sup>	Orifice Diameter
3/8	C	2.16	13/16	3/8 NPT	0.348
1/2	D	2.71	1-1/8	1/2 NPT	0.464
3/4	F	2.95	1-1/4	3/4 NPT	0.593
1	H	3.64	1-5/8	1 NPT	0.890
1-1/4	I	3.91	2-1/4	1-1/4 NPT	1.135
1-1/2	J	4.36	2-1/2	1-1/2 NPT	1.385
2	K	5.85	3	2 NPT	1.555
2-1/2	L	5.50	3-3/4	2-1/2 NPT	1.555
3	M	6.25	4-1/2	3 NPT	2.025
4	N	7.13	5-1/2	4 NPT	2.560

<sup>①</sup> May be larger and/or round.

<sup>②</sup> Consult factory for ISO 7 “Rp” threads.

Body Material <sup>③</sup>	Availability	Non-Shock Pressure-Temperature Rating	
316 Stainless Steel (SS)	Standard	3/8 - 3	4
Carbon Steel (CS)			
Brass (BR)			
Alloy 20 (A2)	Semi-standard	3000 PSIG @ 100°F (1500 PSIG for o-ring seats)	1500 PSIG @ 100°F
Hastelloy® C (HC)			
Mone® (MO)			
Hastelloy® B (HB)	Contact the factory for availability of these or other materials		
Titanium (TI)			

<sup>③</sup> See page 51 for material grade information.

**Universal Low Pressure**  
For Water at 72°F

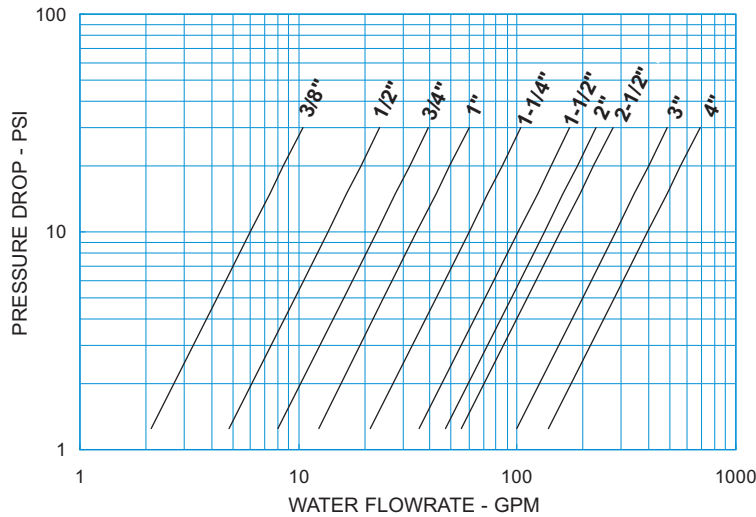

**Note:** All flow curves and Cv values presume the valves are fully open with 1/2 PSI cracking pressure springs. Consult the factory for more information.

STYLE UN-3 (U3)			
C <sub>v</sub> VALUES & VALVE WEIGHTS			
C <sub>v</sub>	SIZE	SS & CS	BRASS
1.9	3/8	3.0 oz.	3.3 oz.
4.3	1/2	8.5 oz.	9.1 oz.
7.2	3/4	9.6 oz.	10.1 oz.
11.0	1	1.2 lb.	1.3 lb.
19.0	1-1/4	2.9 lb.	3.2 lb.
31.9	1-1/2	3.6 lb.	3.9 lb.
42.0	2	6.5 lb.	7.2 lb.
50.0	2-1/2	9.2 lb.	10.0 lb.
89.0	3	14.3 lb.	15.5 lb.
140	4	21.5 lb.	23.3 lb.

See page 46 for Flow Formulae

**HOW TO ORDER**  
**CHECK-ALL STYLE UN-3 (U3)**

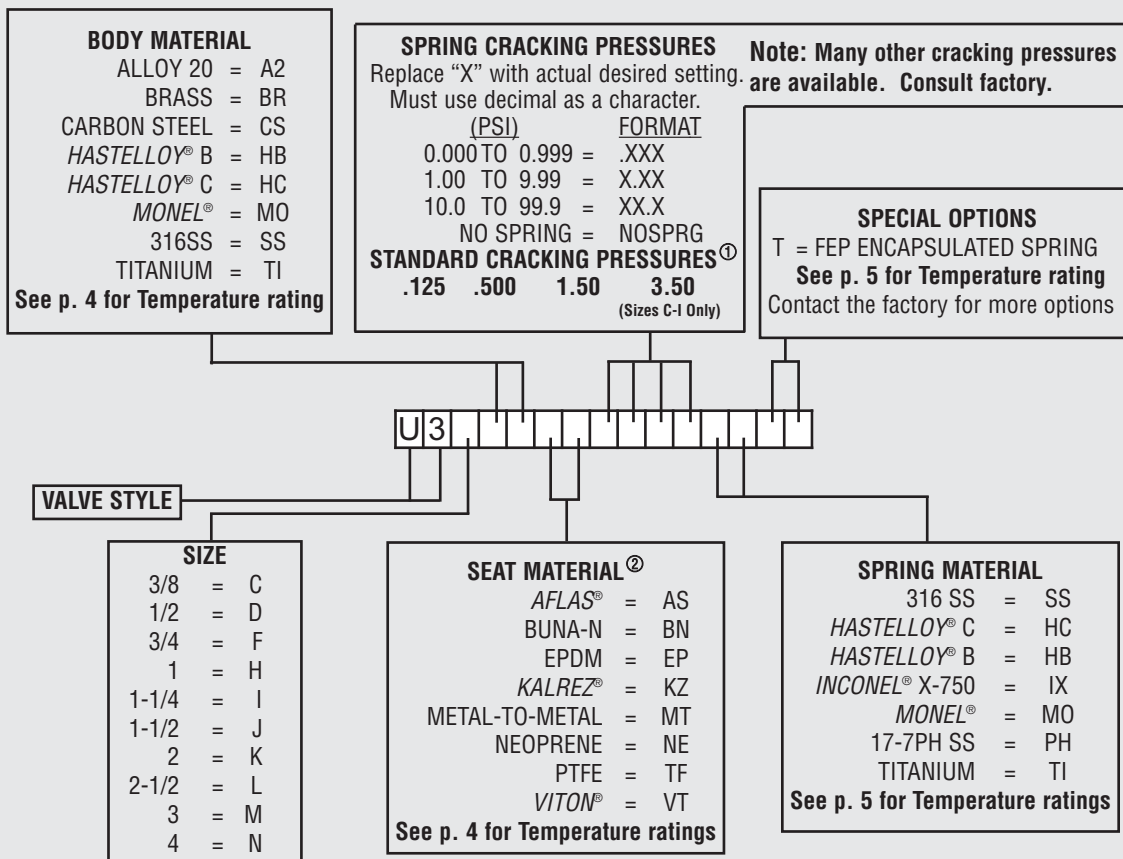

Listed above are the most common material selections. Please contact the factory for additional options.

① .500 PSI is the only standard cracking pressure for spring materials other than Stainless Steel. Cracking pressure tolerance is +/- 15%. .125 PSI springs are not recommended for installations with flow vertical down.

② Seat materials other than metal-to-metal have a maximum pressure rating of 1500 PSI. PTFE seats are not resilient. See page 47 for allowable leakage rates.

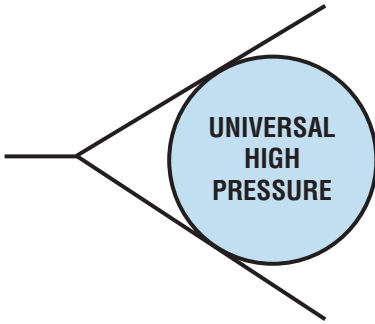

The **Universal High Pressure** check valve is a one piece body machined from bar stock with female pipe threads. The valve is designed and manufactured for high pressure applications. This valve is normally supplied with a metal to metal seat. Also available with ISO 7 “Rp” threads.

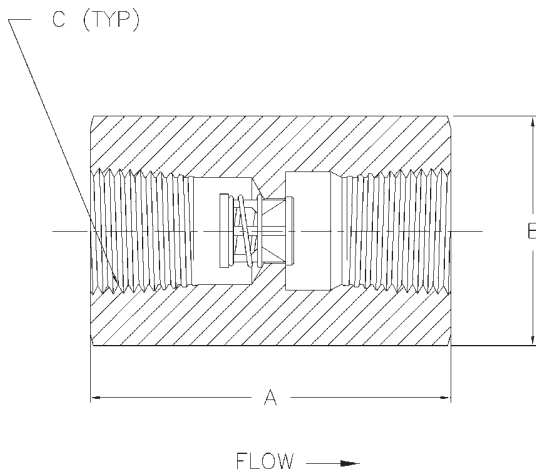

Nom. Pipe Size	Size Code	A	Hex <sup>①</sup> Size B	C <sup>②</sup>	Orifice Diameter
3/8	C	2.16	1	3/8 NPT	0.348
1/2	D	2.70	1-1/4	1/2 NPT	0.464
3/4	F	2.94	1-5/8	3/4 NPT	0.593
1	H	3.63	2-1/4	1 NPT	0.890
1-1/4	I	3.91	2-3/4	1-1/4 NPT	1.135
1-1/2	J	4.36	3-1/4	1-1/2 NPT	1.385

<sup>①</sup>May be larger and/or round.

<sup>②</sup>Consult factory for ISO 7 “Rp” threads.

Body Material <sup>③</sup>	Availability	Non-Shock Pressure-Temperature Rating
316 Stainless Steel (SS)	Standard	10,000 PSIG @ 100°F
Carbon Steel (CS)		
Alloy 20 (A2)	Semi-standard	
Hastelloy® C (HC)		
Monel® (MO)		
Hastelloy® B (HB)	Contact the factory for availability of these or other materials	
Titanium (TI)		

<sup>③</sup>See page 51 for material grade information.

**Note:** All flow curves and Cv values presume the valves are fully open with 1/2 PSI cracking pressure springs. Consult the factory for more information.

**Universal High Pressure**  
For Water at 72°F

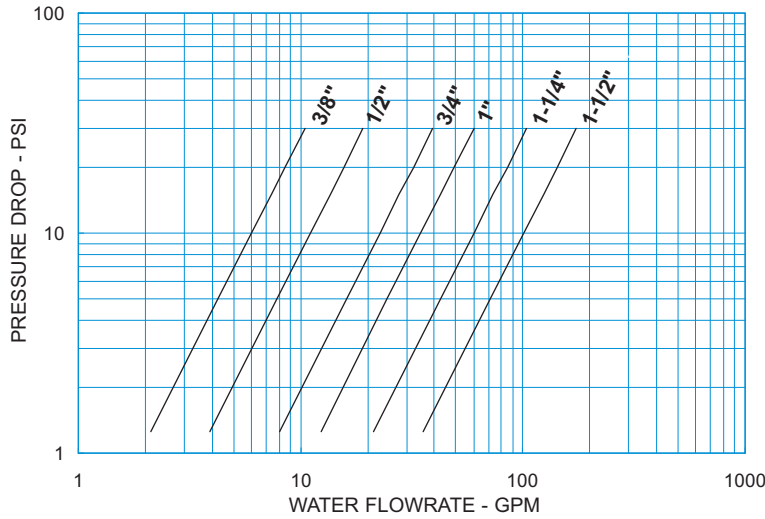

STYLE UN-10 (U1) C <sub>v</sub> VALUES & VALVE WEIGHTS		
C <sub>v</sub>	SIZE	SS & CS
1.9	3/8	5.9 oz.
3.5	1/2	11.8 oz.
7.2	3/4	1.4 lb.
11.0	1	3.5 lb.
19.0	1-1/4	5.4 lb.
31.9	1-1/2	8.1 lb.

See page 46 for Flow Formulae

**HOW TO ORDER**  
**CHECK-ALL STYLE UN-10 (U1)**

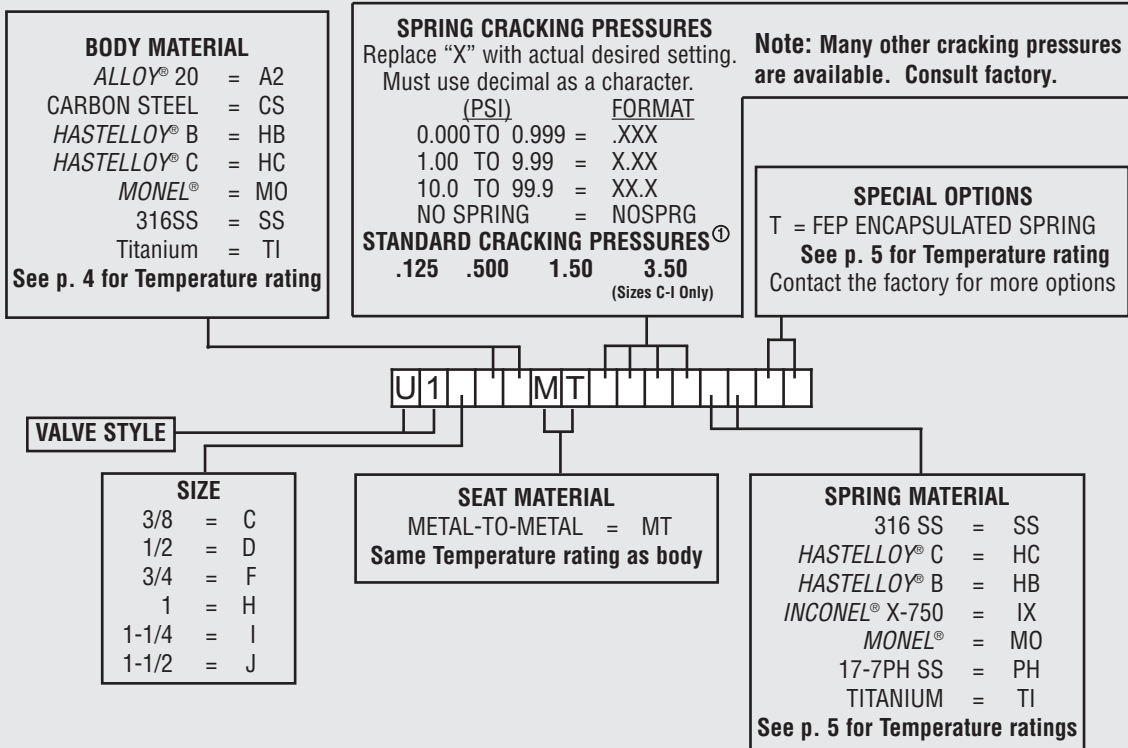

Listed above are the most common material selections. Please contact the factory for additional options.

① .500 PSI is the only standard cracking pressure for spring materials other than Stainless Steel. Cracking pressure tolerance is +/- 15%. .125 PSI springs are not recommended for installations with flow vertical down.

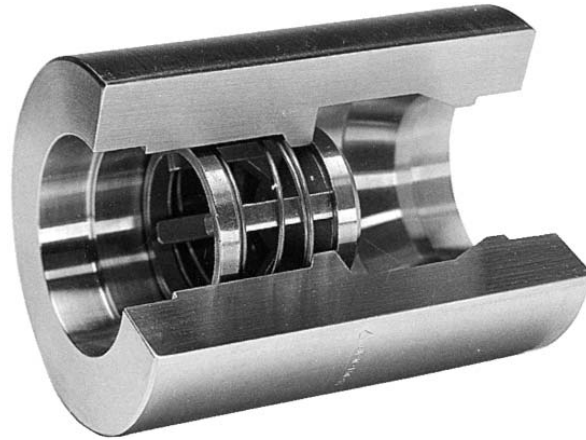
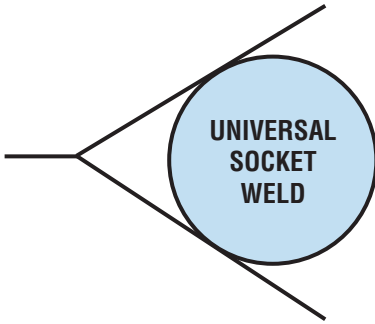

The **Universal Socket Weld** check valve is a one piece body machined from bar stock with socket weld ends and is designed for a minimum pressure drop. It carries rugged, dependable Check-All trim and there are a wide variety of seat materials and cracking pressures to choose from. The socket parts are machined to ANSI B16.11 dimensions.

**NOTE:** Please take precautionary measures when welding to prevent heat build-up and possible damage to the valve seat. See page 48 for additional installation information.

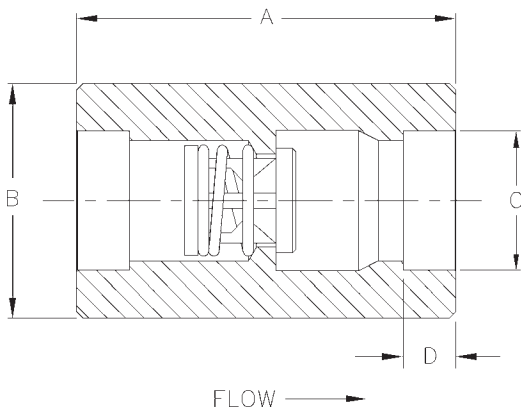

Nom. Pipe Size	Size Code	A	B <sup>①</sup>	C <sup>②</sup>	D <sup>②</sup>	Orifice Diameter
3/8	C	2.16	1-1/8	0.695	0.385	0.348
1/2	D	2.71	1-5/16	0.860	0.385	0.464
3/4	F	2.95	1-5/8	1.070	0.505	0.593
1	H	3.64	2-1/4	1.335	0.505	0.890
1-1/4	I	3.91	2-3/4	1.680	0.505	1.135
1-1/2	J	4.36	3-1/4	1.920	0.505	1.385
2	K	5.85	3-1/2	2.411	0.625	1.555
2-1/2	L	5.00	3-3/4	2.919	0.625	1.555
3	M	5.44	4-1/2	3.545	0.625	2.025
4	N	6.80	5-1/2	4.550	0.755	2.560

<sup>①</sup>May be larger and/or hex.

<sup>②</sup>Sockets per ASME/ANSI B16.11.

Body Material <sup>③</sup>	Availability	Non-Shock Pressure Rating		
316/316L Stainless Steel (SS)	Standard	3/8 - 2-1/2	3	4
Carbon Steel (CS)				
Alloy 20 (A2)	Semi-standard	5000 PSIG @ 100°F (1500 PSIG for o-ring seats)	3000 PSIG @ 100°F (1500 PSIG for o-ring seats)	1500 PSIG @ 100°F
Hastelloy® C (HC)				
Mone® (MO)				
Hastelloy® B (HB)	Contact the factory for availability of these or other materials			
Titanium (TI)				

<sup>③</sup>See page 51 for material grade information.

**Universal Socket Weld**  
For Water at 72°F

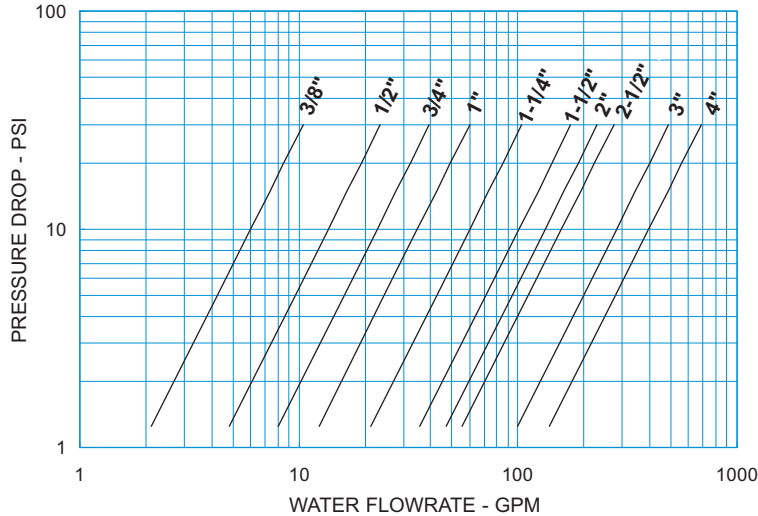

**Note:** All flow curves and Cv values presume the valves are fully open with 1/2 PSI cracking pressure springs. Consult the factory for more information.

STYLE UN-SW (US) C <sub>v</sub> VALUES & VALVE WEIGHTS		
C <sub>v</sub>	SIZE	SS & CS
1.9	3/8	5.1 oz.
4.3	1/2	11.5 oz.
7.2	3/4	1.2 lb.
11.0	1	3.1 lb.
19.0	1-1/4	4.9 lb.
31.9	1-1/2	7.4 lb.
42.0	2	9.8 lb.
50.0	2-1/2	8.8 lb.
89.0	3	13.0 lb.
140	4	22.3 lb.

See page 46 for Flow Formulae

**HOW TO ORDER**  
**CHECK-ALL STYLE UN-SW (US)**

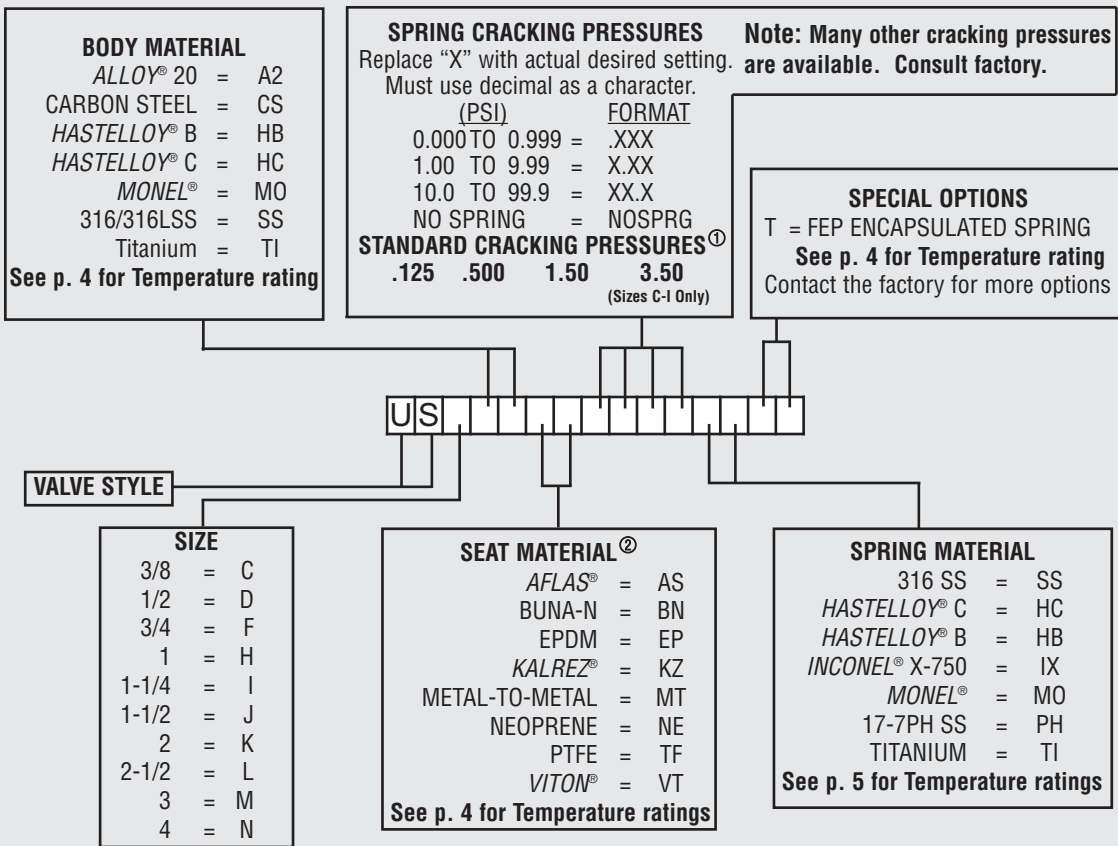

Listed above are the most common material selections. Please contact the factory for additional options.

<sup>①</sup>.500 PSI is the only standard cracking pressure for spring materials other than Stainless Steel. Cracking pressure tolerance is +/- 15%. .125 PSI springs are not recommended for installations with flow vertical down.

<sup>②</sup>Seat materials other than metal-to-metal have a maximum pressure rating of 1500 PSI. PTFE seats are not resilient. See page 47 for allowable leakage rates.



PED 97/23/EC  
COMPLIANT  
See Page 52 for Details

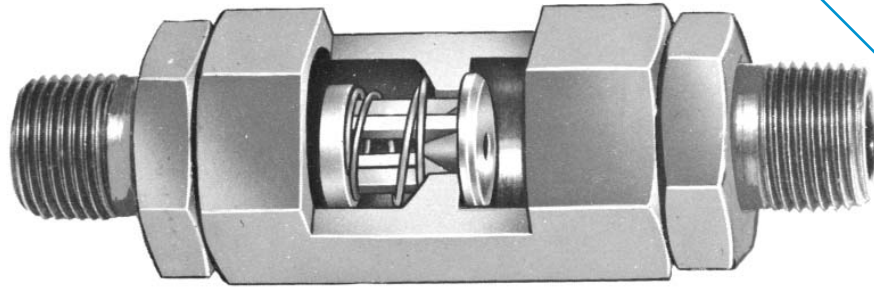
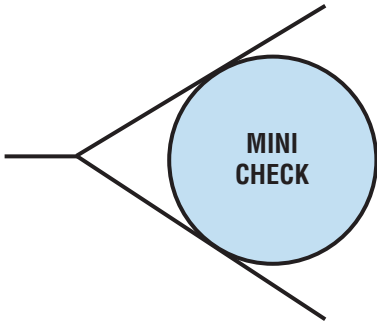

The **Mini-Check** is designed for minimum pressure drops. The three-piece construction permits many combinations of end fittings, which makes the valve adaptable for nearly every application. The Mini-Check is available with 1/8, 1/4 and 3/8 inch pipe threads, both male and female. It can also be supplied with a 1/4 or 3/8 inch **tubing end** on one side and with a **pipe thread end** on the other. **Combinations** of male and female threads are also available. Consult the factory for more information.

- M1 – Male pipe threads both ends.
- M2 – Female pipe threads both ends.
- M3 – Male pipe **inlet** – female pipe **outlet**.
- M4 – Female pipe **inlet** – male pipe **outlet**.

- M5 – Male pipe **inlet** – tubing **outlet**.
- M6 – Female pipe **inlet** – tubing **outlet**.
- M7 – Tubing **inlet** – male pipe **outlet**.
- M8 – Tubing **inlet** – female pipe **outlet**.

**NOTE:** When ordering styles M5 through M8 be sure to specify tubing size and whether **compression or 37° flare**.

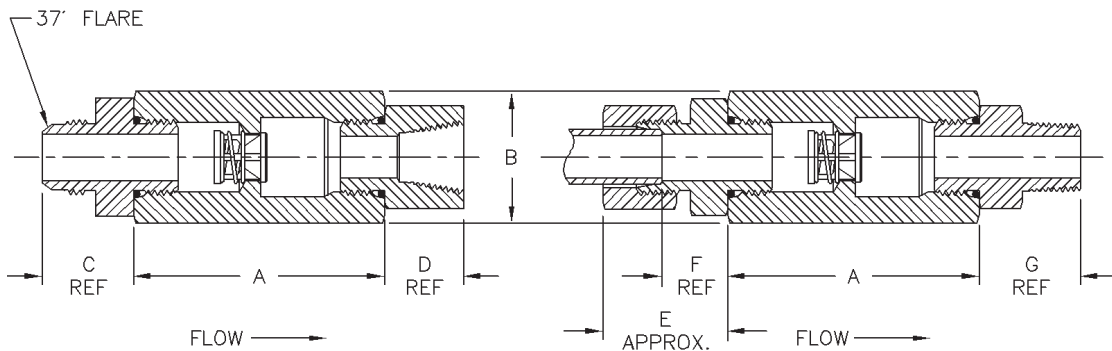

Nom. Pipe & Tube Size	Size Code	A	Hex Size B <sup>①</sup>	C	D	E	F	G	Orifice Diameter
1/8	A	2.16	7/8	N/A	0.71	N/A	N/A	0.71	0.348
1/4	B	2.16	7/8	0.89	0.84	1.23	0.57	0.95	0.348
3/8	C	2.48	1-1/8	0.94	0.91	1.32	0.59	1.00	0.464

<sup>①</sup>May be larger and/or round.

Body Material <sup>②</sup>	Non-Shock Pressure-Temperature Rating <sup>③</sup>
316 Stainless Steel (SS)	5000 PSIG @ 100°F
Carbon Steel (CS)	
Brass (BR)	3000 PSIG @ 100°F

<sup>②</sup>See page 51 for material grade information.

<sup>③</sup>Maximum Pressure 1500 PSI for o-ring seats.

### Mini Check

For Water at 72°F

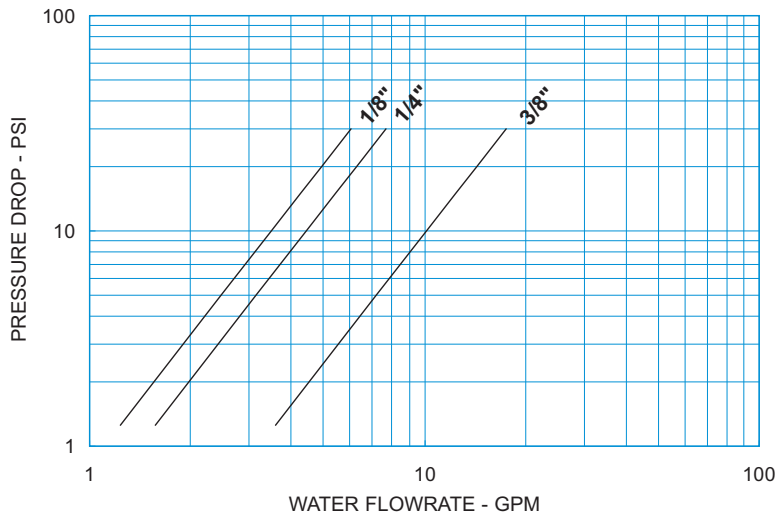

**Note:** All flow curves and Cv values presume the valves are fully open with 1/2 PSI cracking pressure springs. Consult the factory for more information.

STYLE MCV (M1-M8) C <sub>v</sub> VALUES & VALVE WEIGHTS		
C <sub>v</sub>	SIZE	ALL MATL
1.1	1/8	6.2 oz.
1.4	1/4	7.3 oz.
3.2	3/8	11.8 oz.

See page 46 for Flow Formulae

## HOW TO ORDER CHECK-ALL STYLE MCV (M1 - M8)

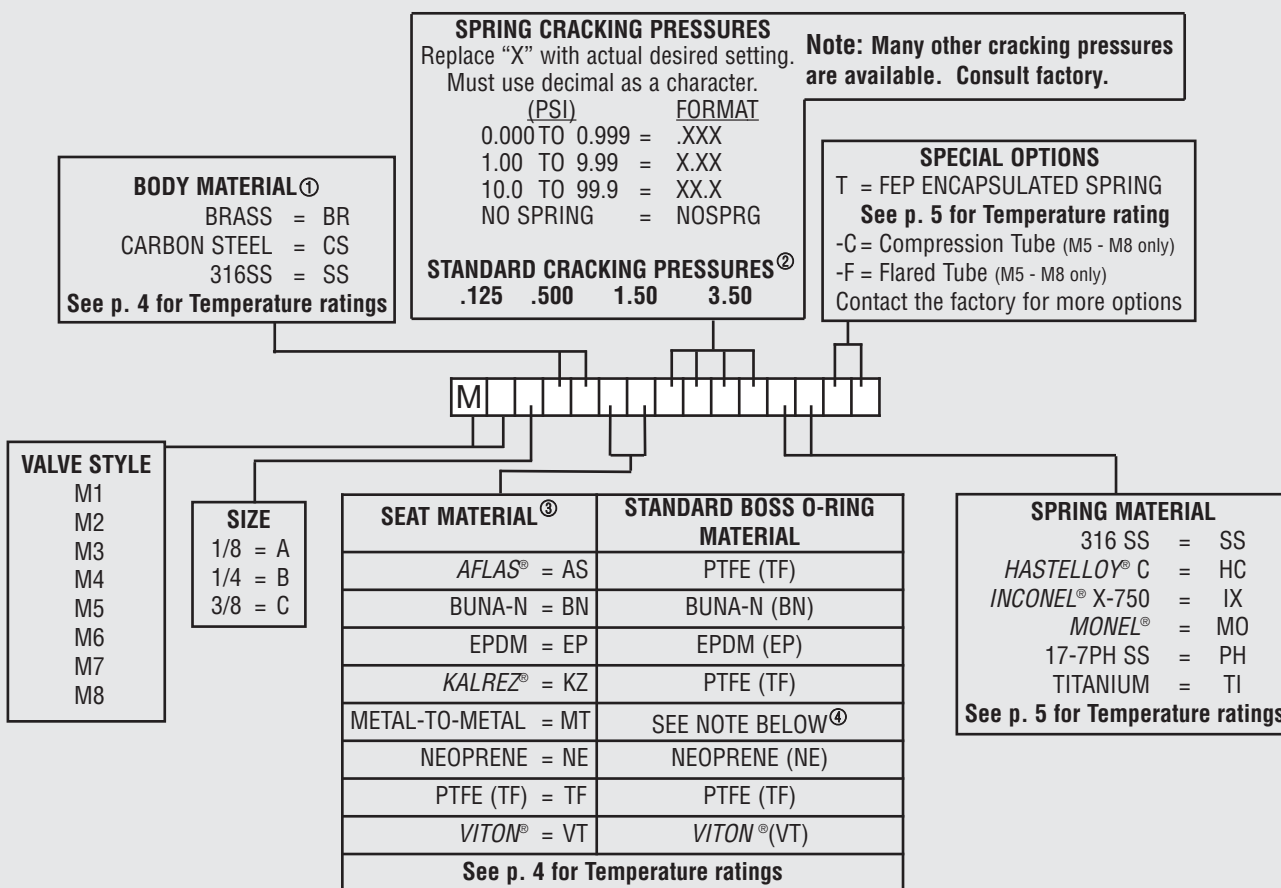

Listed above are the most common material selections. Please contact the factory for additional options.

- ① Brass valves have plated Carbon Steel tube fittings if applicable. Consult factory if other body or fitting materials are desired.
- ② .500 PSI is the only standard cracking pressure for spring materials other than Stainless Steel. Cracking pressure tolerance is +/- 15%. .125 PSI springs are not recommended for installations with flow vertical down.
- ③ Seat materials other than metal-to-metal have a maximum pressure rating of 1500 PSI. PTFE seats are not resilient. See page 47 for allowable leakage rates.
- ④ Brass and Carbon Steel valves have Buna-N boss o-rings, 316SS valves have Viton® boss o-rings.

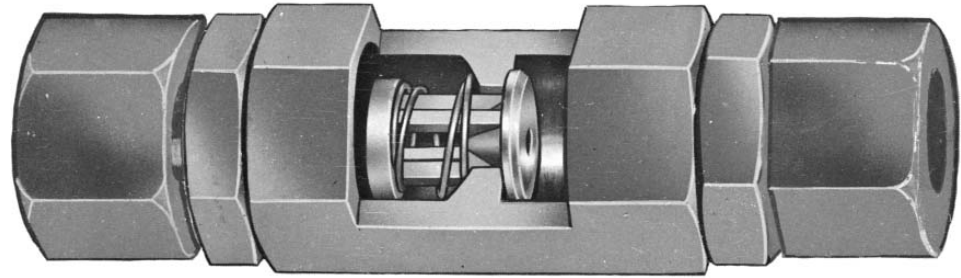
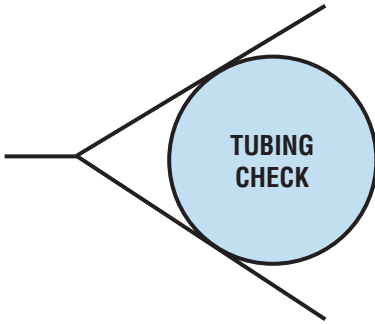

The **Tubing Check** valve is constructed with **flareless** tube ends designed for minimum pressure drop. The valves are furnished complete with ferrules and nuts. Consult the factory for more information.

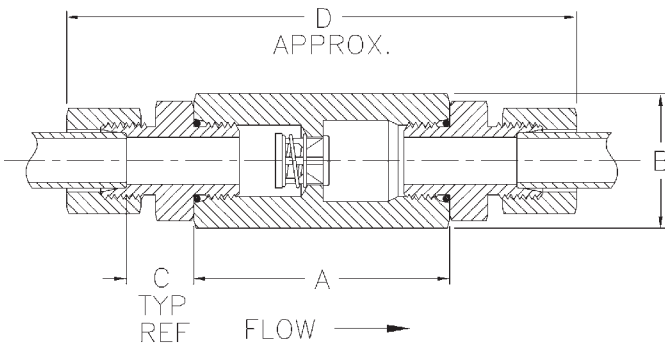

Tubing O.D. Size	Size Code	A	Hex <sup>①</sup> Size B	C	D	Orifice Diameter
1/4	B	2.16	7/8	0.57	4.58	0.348
3/8	C	2.16	7/8	0.57	4.80	0.348
1/2	D	2.48	1-1/8	0.63	5.44	0.464
5/8*	E	2.63	1-1/4	0.72	5.89	0.464
3/4	F	2.93	1-1/2	0.85	6.47	0.593
7/8*	G	3.34	1-3/4	0.85	6.98	0.890
1	H	3.34	1-7/8	0.81	7.18	0.890
1-1/4*	I	3.48	2-1/4	0.89	7.56	1.135
1-1/2*	J	3.81	2-1/2	0.89	7.99	1.385
2*	K	5.09	3-1/2	1.05	9.66	2.025

<sup>①</sup>May be larger and/or round.  
 \*Not a stock item. Consult factory for delivery.

Line Size	Non-Shock Pressure Rating <sup>②</sup>		
	Stainless Steel (SS) <sup>③</sup>	Carbon Steel (CS) <sup>③</sup>	Brass (BR) <sup>③</sup>
1/4 - 1/2	8500 PSIG @ 100°F	7000 PSIG @ 100°F	2000 PSIG @ 100°F
5/8 - 1	6600 PSIG @ 100°F	5000 PSIG @ 100°F	1600 PSIG @ 100°F
1-1/4 - 1-1/2	4800 PSIG @ 100°F	4000 PSIG @ 100°F	1600 PSIG @ 100°F
2	3000 PSIG @ 100°F	2500 PSIG @ 100°F	1600 PSIG @ 100°F

<sup>②</sup>Maximum Pressure 1500 PSIG for o-ring seats.  
<sup>③</sup>See page 51 for material grade information.

**Tubing Check**  
For Water at 72°F

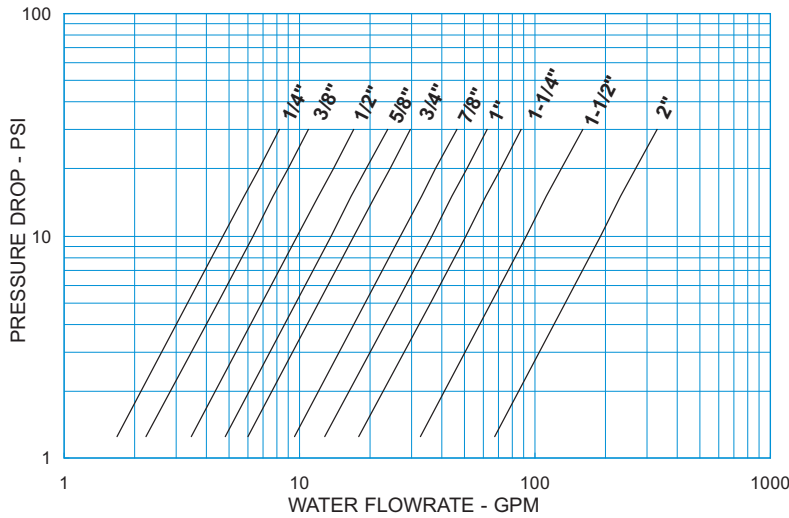

**Note:** All flow curves and Cv values presume the valves are fully open with 1/2 PSI cracking pressure springs. Consult the factory for more information.

STYLE TCV (TV) C <sub>v</sub> VALUES & VALVE WEIGHTS		
C <sub>v</sub>	SIZE	ALL MATL
1.5	1/4	6.6 oz.
2.0	3/8	7.2 oz.
3.1	1/2	13.0 oz.
4.3	5/8	1.8 lb.
5.4	3/4	2.3 lb.
8.5	7/8	2.7 lb.
11.5	1	3.0 lb.
16.0	1-1/4	5.7 lb.
29.0	1-1/2	7.8 lb.
60.0	2	15.0 lb.

See page 46 for Flow Formulae

**HOW TO ORDER  
CHECK-ALL STYLE TCV (TV)**

**BODY MATERIAL** ①

BRASS = BR  
CARBON STEEL = CS  
316SS = SS

See p. 4 for Temperature ratings

**SPRING CRACKING PRESSURES**

Replace "X" with actual desired setting.  
Must use decimal as a character.

(PSI)	FORMAT
0.000 TO 0.999 =	.XXX
1.00 TO 9.99 =	X.XX
10.0 TO 99.9 =	XX.X
NO SPRING =	NOSPRG

**STANDARD CRACKING PRESSURES** ②

.125	.500	1.50	3.50
(Sizes B-I Only)			

**SPECIAL OPTIONS**

T = FEP ENCAPSULATED SPRING

See p. 5 for Temperature ratings

Contact the factory for more options

VALVE STYLE

TV

**SIZE**

1/4 = B  
3/8 = C  
1/2 = D  
5/8 = E  
3/4 = F  
7/8 = G  
1 = H  
1-1/4 = I  
1-1/2 = J  
2 = K

SEAT MATERIAL	STANDARD BOSS O-RING MATERIAL
AFLAS® = AS	PTFE (TF)
BUNA-N = BN	BUNA-N (BN)
EPDM = EP	EPDM (EP)
KALREZ® = KZ	PTFE (TF)
METAL-TO-METAL = MT	SEE NOTE BELOW ④
NEOPRENE = NE	NEOPRENE (NE)
PTFE (TF) = TF	PTFE (TF)
VITON® = VT	VITON®(VT)

**SPRING MATERIAL**

316 SS = SS  
HASTELLOY® C = HC  
INCONEL® X-750 = IX  
MONEL® = MO  
17-7PH SS = PH  
TITANIUM = TI

See p. 5 for Temperature ratings

See p. 4 for Temperature ratings

Listed above are the most common material selections. Please contact the factory for additional options.

- ① Brass valves have plated Carbon Steel fittings. Consult factory if other body or fitting materials are desired.
- ② .500 PSI is the only standard cracking pressure for spring materials other than Stainless Steel. Cracking pressure tolerance is +/- 15%. .125 PSI springs are not recommended for installations with flow vertical down.
- ③ Seat materials other than metal-to-metal have a maximum pressure rating of 1500 PSI. PTFE seats are not resilient. See page 47 for allowable leakage rates.
- ④ Brass and Carbon Steel valves have Buna-N boss o-rings, 316SS valves have Viton® boss o-rings.

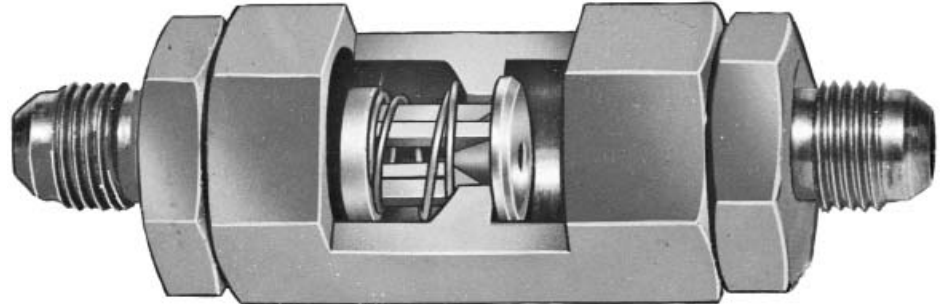
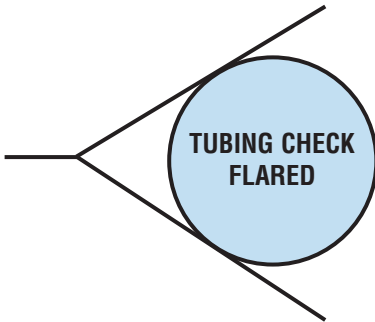

The **Tubing Check Valve-Flared** is a three-piece constructed check valve with 37° flared end fittings that conform to SAE J514 & ISO 8434-2 . These valves are designed for maximum flow with minimal pressure drop. Consult the factory for more information.

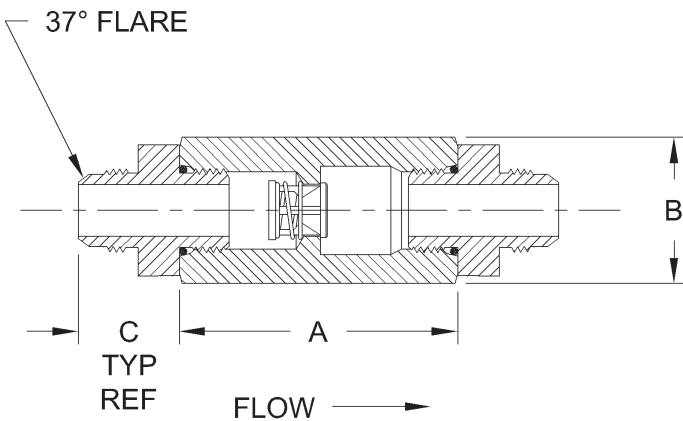

Tubing O.D. Size	Size Code	A	Hex <sup>①</sup> Size B	C	Orifice Diameter
1/4	B	2.16	7/8	0.89	0.348
3/8	C	2.16	7/8	0.91	0.348
1/2	D	2.47	1-1/8	1.04	0.464
5/8*	E	2.63	1-1/4	1.20	0.464
3/4	F	2.92	1-1/2	1.38	0.593
7/8*	G	3.33	1-3/4	1.40	0.890
1	H	3.33	1-7/8	1.46	0.890
1-1/4*	I	3.48	2-1/4	1.58	1.135
1-1/2*	J	3.80	2-1/2	1.79	1.385
2*	K	5.09	3-1/2	2.19	2.025

<sup>①</sup>May be larger and/or round.

\*Not a stock item. Consult factory for delivery.

Line Size	Non-Shock Pressure Rating <sup>②</sup>		
	Stainless Steel (SS) <sup>③</sup>	Carbon Steel (CS) <sup>③</sup>	Brass (BR) <sup>③</sup>
1/4 - 1/2	8500 PSIG @ 100°F	7000 PSIG @ 100°F	2000 PSIG @ 100°F
5/8 - 1	6600 PSIG @ 100°F	5000 PSIG @ 100°F	1600 PSIG @ 100°F
1-1/4 - 1-1/2	5800 PSIG @ 100°F	4600 PSIG @ 100°F	1600 PSIG @ 100°F
2	3000 PSIG @ 100°F	2500 PSIG @ 100°F	1600 PSIG @ 100°F

<sup>②</sup>Maximum Pressure 1500 PSIG for o-ring seats.

<sup>③</sup>See page 51 for material grade information.

**Tubing Check Valve Flared**  
For Water at 72°F

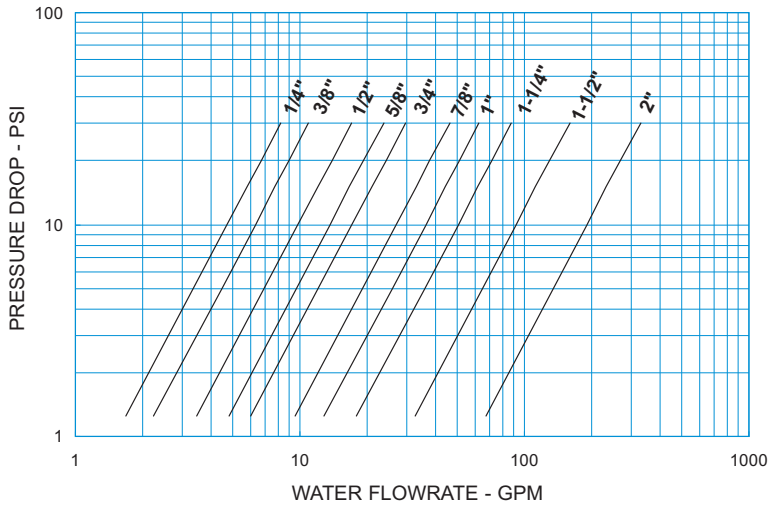

**Note:** All flow curves and Cv values presume the valves are fully open with 1/2 PSI cracking pressure springs. Consult the factory for more information.

STYLE TCVF (TF) C <sub>v</sub> VALUES & VALVE WEIGHTS		
C <sub>v</sub>	SIZE	ALL MATL
1.5	1/4	6.6 oz.
2.0	3/8	7.2 oz.
3.1	1/2	13.0 oz.
4.3	5/8	1.8 lb.
5.4	3/4	2.3 lb.
8.5	7/8	2.7 lb.
11.5	1	3.0 lb.
16.0	1-1/4	5.7 lb.
29.0	1-1/2	7.8 lb.
60.0	2	15.0 lb.

See page 46 for Flow Formulae

**HOW TO ORDER  
CHECK-ALL STYLE TCVF (TF)**

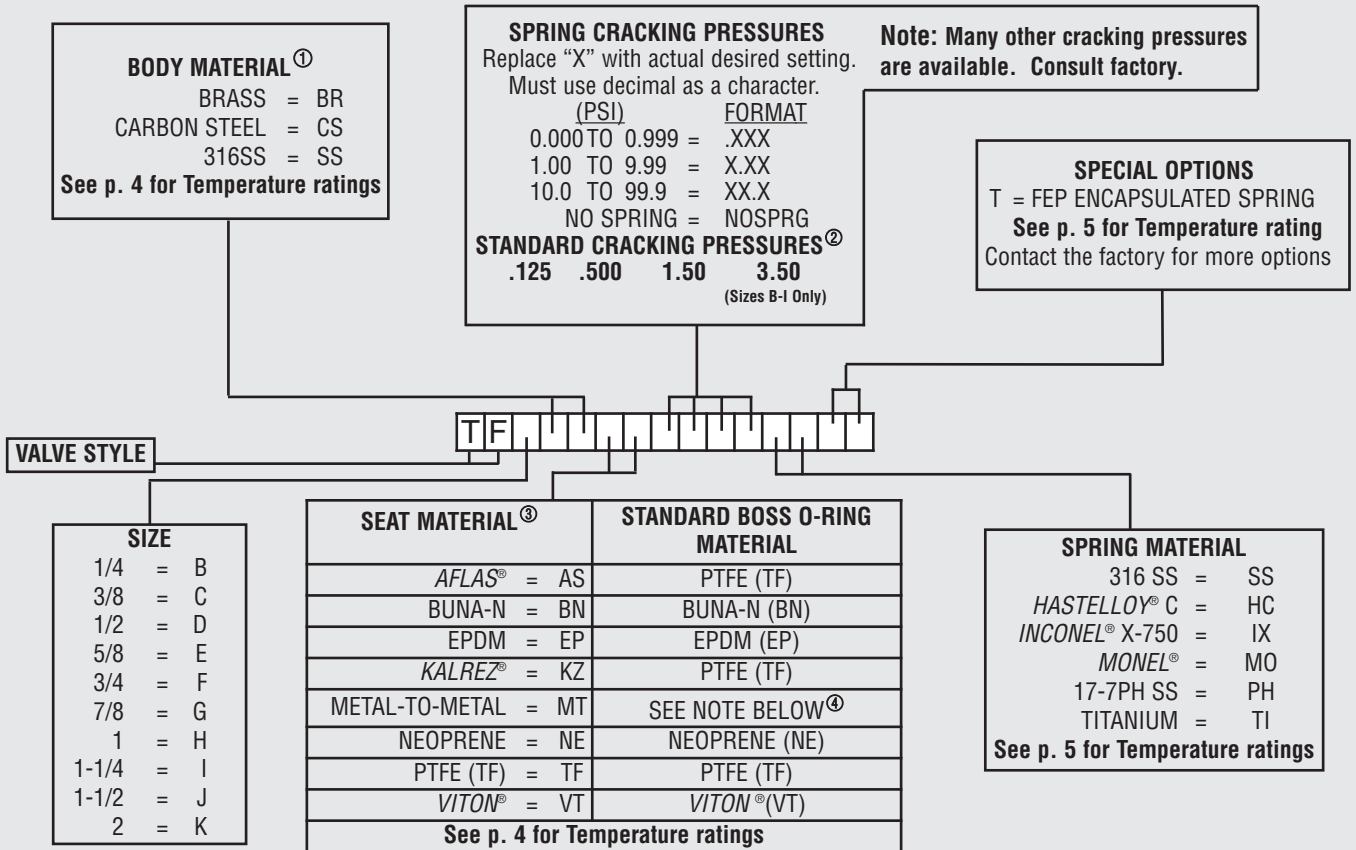

Listed above are the most common material selections. Please contact the factory for additional options.

- ① Brass valves have plated Carbon Steel fittings. Consult factory if other body or fitting materials are desired.
- ② .500 PSI is the only standard cracking pressure for spring materials other than Stainless Steel. Cracking pressure tolerance is +/- 15%. .125 PSI springs are not recommended for installations with flow vertical down.
- ③ Seat materials other than metal-to-metal have a maximum pressure rating of 1500 PSI. PTFE seats are not resilient. See page 47 for allowable leakage rates.
- ④ Brass and Carbon Steel valves have Buna-N boss o-rings, 316SS valves have Viton® boss o-rings.

# TECHNICAL DATA

**Valve Sizing** – Check-All furnishes two methods to aid the customer in the selection of the correct valve size to meet their flow requirements; **Flow Curves and  $C_V$  Factor**.

**Flow Curves** show the relationship between the rate of flow (water, gpm) and the pressure drop across the valve produced by that flow.

**$C_V$  Factor** is a valve flow coefficient which mathematically gives the relationship between the rate of flow and the pressure drop.

**Definition:  $C_V$**  is defined as the quantity of water, in gallons per minute, which will pass through a specific valve at maximum lift, at one (1) psi pressure drop.

It is experimentally determined by dividing the water flow through the valve by the square root of the pressure drop produced by that flow. Conversely, given the  $C_V$ , the water flow through the valve at any given pressure drop may be calculated by multiplying the  $C_V$  by the square root of the pressure drop. Therefore, for a given pressure drop, the higher the  $C_V$ , the higher the rate of flow.

For liquids other than water, for gases and for saturated steam, the formulae given below will show the relationship between the  $C_V$  (as obtained from water flow tests) and the flow of these fluids.

## FLOW FORMULAE

(Non-Choked Turbulent Flow Only)

### I. LIQUIDS

$$V = C_V \sqrt{\frac{dP}{G}}$$

$$dP = \left( \frac{V}{C_V} \right)^2 G$$

$$C_V = \frac{V}{\sqrt{\frac{dP}{G}}}$$

Where  $V$  = Liquid flow (gpm)  
 $dP$  = Pressure drop (psi)  
 $G$  = Sp. Gravity of liquid (water = 1.0)  
 $C_V$  = Valve coefficient

### II. GASSES

$$Q = 1360 C_V \sqrt{\frac{dP}{GT}} \sqrt{\frac{P_1 + P_2}{2}}$$

$$dP = P_1 - \sqrt{P_1^2 - 2GT \left( \frac{Q}{1360 C_V} \right)^2}$$

$$C_V = \frac{Q}{1360 \sqrt{\frac{dP}{GT}} \sqrt{\frac{P_1 + P_2}{2}}}$$

Where  $Q$  = Gas flow (scfh)  
 $dP$  = Pressure drop (psi)<sup>1</sup>  
 $T$  = Absolute temp of flowing medium (degrees Rankin)  
 $P_1$  = Inlet pressure (psia)  
 $P_2$  = Outlet pressure (psia)  
 $C_V$  = Valve coefficient  
 $G$  = Sp. Gravity of gas (air = 1.0)

### III. SATURATED STEAM

$$W = 3 C_V \sqrt{dP} \sqrt{\frac{P_1 + P_2}{2}}$$

$$dP = P_1 - \sqrt{P_1^2 - 2 \left( \frac{W}{3 C_V} \right)^2}$$

$$C_V = \frac{W}{3 \sqrt{dP} \sqrt{\frac{P_1 + P_2}{2}}}$$

Where  $W$  = Saturated steam flow (lbs. per hour)  
 $dP$  = Press drop (psi)<sup>1</sup>  
 $P_1$  = Inlet pressure (psia)  
 $P_2$  = Outlet pressure (psia)  
 $C_V$  = Valve coefficient

<sup>1</sup> – For calculation purposes,  $dP$  should never exceed 1/2 the inlet pressure,  $P_1$ .

# Check-All Valve Application Guidelines

The following information is provided to assist in the selection of components when specifying or using Check-All Valve products. It is presented for general information only and should not be considered an all inclusive list, nor should it replace the on-sight process engineering required to properly apply any valve.

## Installation/Mounting

Check-All valves can be used in horizontal or vertical applications with proper spring selection. This is most evident in vertical flow down installations. The spring selected must be heavy enough to support the weight of the trim in addition to any column of liquid desired to be retained. Consult the factory or your local Check-All Valve representative for further information.

## Elbow, Tee or other Flow Skewing Device

Check-All valves are best suited for use with fully developed flow. Although there are many factors affecting the achievement of fully developed flow (such as media, pipe roughness, and velocity) usually 10 pipe diameters of straight pipe immediately upstream of the valve is sufficient. This is particularly important after flow skewing devices such as elbows, tees, centrifugal pumps, etc.

## Valve Material Selection

There are many factors that influence the resistance of materials to corrosion, such as temperature, concentration, aeration, contaminants, and media interaction/reaction. Check-All Valve will provide any assistance it can regarding the selection of products; however, the decision as to specific application of the valves and the materials of construction is beyond the scope of supply of Check-All Valve products. This is the sole responsibility of the customer based upon his or her own evaluation.

## Seat Material Selection

Several seat material options are available for Check-All valves. The allowable leakage rate associated with the metal-to-metal as well as the PTFE o-ring seat, is 190 cc/min per inch of line size, when tested with air at 80 PSI. Resilient o-ring seats are available for a tighter shut-off (no visible leakage allowed at 80 PSI air). All o-ring seats are limited to a maximum operating pressure of 1500 PSI.

## Sizing and Spring Selection

Check-All Valve recommends sizing check valves to ensure proper valve operation and service life. Valves can be sized using the equations on page 46. **Sizing accuracy requires the valve be fully open, which occurs when the pressure drop across the valve reaches or exceeds three times the spring cracking pressure (five times for 3SC valves).** Contact the factory or your local Check-All Valve representative for further information or assistance.

## Shock-Load Applications

Check-All valves are not designed for use in a shock-load environment, such as the discharge of a reciprocating air compressor. These types of applications produce excessive impact stresses which can adversely affect valve performance.

## Fluid Quality

Check-All valves are best suited for clean, particle-free liquids or gasses. Debris such as sand or fibers can prevent the valve from sealing properly or it can erode internal components or otherwise adversely affect valve travel. These particles should be filtered out prior to entering the valves.

## Insert Series Valves

Check-All Insert series valves such as the FIV, LPI, UIV, etc. are designed to use the existing pipe as part of the valve body. This provides a very cost effective solution for valve requirements. As such, part of the valve functions inside the existing pipe; therefore, dimensional clearance must be maintained for proper valve operation. See the pertinent catalog pages or contact the factory or your local Check-All representative for more information.

# INSTALLATION AND OPERATING INSTRUCTIONS

WARNING!!! READ ALL OF THESE INSTRUCTIONS BEFORE PROCEEDING! ONLY EXPERIENCED PERSONNEL SHOULD BE ALLOWED TO INSTALL OR HANDLE THE ENCLOSED VALVE(S). ANY DAMAGE RESULTING FROM MISHANDLING OR IMPROPER INSTALLATION IS NOT COVERED BY THE MANUFACTURERS WARRANTY. FOR WARRANTY DETAILS, REFER TO THE LATEST REVISION OF CHECK-ALL VALVE MANUFACTURING COMPANY MANUFACTURER'S TERMS AND CONDITIONS (Form #160) page 56.

The following instructions are meant as a guideline only. They do not cover every situation and rely on the common sense and expertise of the person installing the valve. In no way is Check-All liable for any damage to the valve, the system, or for personal injury resulting from use of these guidelines.

## GENERAL INSTRUCTIONS

- Inspection. Prior to installation, inspect valves for any damage. Refer to Check-All Valve Terms and Conditions page 56 for warranty information.
- Flow arrows. Install each check valve in the line with the arrow pointing in the direction of the flow. To verify proper installation, make sure each valve opens in the direction of desired flow. Note: From the closed position the poppet moves away from the seat in the direction of flow.
- Valve support. Valves must be adequately supported with pipe hangers, etc. to prevent additional loading on the valve body.
- Alignment & connection. Refer to ASME B31 "Pressure Piping Code" and ASME PCC-1 "Guidelines for Pressure Boundary Bolted Flange Joint Assembly" for recommended guidelines on alignment, bolt torque, etc.
- Safe connection. Valves must be adequately connected (threaded, welded, etc.) to surrounding piping to prevent unsafe discharge during filling and/or operation.
- Insert series valves. Insert series valves may not be visible after installation. It is the end user's responsibility to verify that there is adequate identification of the presence of a check valve installed in the system and to take any necessary precautions to avoid injuries or spills when the line is disassembled for maintenance or other reasons. Please consult the factory or your local Check-All representative for tagging options or further information.
- Intended Use. Valves compliant with the European Union Pressure Equipment Directive (97/23/EC) that have been classified under Sound Engineering Practice may be limited in their use. They will be identified as such with either marking on the valve body or an additional tag. If such classification is marked on an additional tag it is the end-users responsibility to reattach such identification to the installed valve or surrounding piping.

### NPT PIPE THREADED VALVES: CON (CN), UN-3 (U3), UN-10 (U1), BU (BU), AND MCV (M1- M8) SERIES

Handle NPT threads on these valves carefully to avoid damage. Use an anti-seize thread sealant to prevent galling. Note: Because Bushing Series (BU) valves open into downstream connections, ensure adequate clearance for the travel of the poppet.

### VALVES WITH TUBING CONNECTIONS: TCV (TV), TCVF (TF), AND MCV (M5-M8) SERIES

For a valve with flared fittings, slide the nut (not provided with the valve) onto the tubing and flare the tubing end. Tighten the nut onto the flared end of the valve. Note: Leakage can result if the flared surface is damaged. For a valve with compression fittings, first slide the nut on the tubing then the ferrule. Next, insert the tubing end into the valve fitting and tighten the nut. Note: the fittings are supplied as accessories only and as such are not governed by the European Union Pressure Equipment Directive 97/23/EC.

### HVFD (HV) SERIES VALVES

Install each valve between ANSI class 150 raised face flanges with a gasket between each flanged joint and tighten the bolts per gasket manufacturer's torque recommendations.

### HVFD-T (HT) SERIES VALVES

Install each valve between ANSI class 150 raised face flanges (no gaskets are necessary) and tighten the bolts only enough to ensure no leakage. Note: The valve liner may be damaged by over-tightening the bolts and/or by piping systems that add additional loads to the flanged joints.

### FLANGE, LINED PIPE, AND WAFER INSERT VALVES: FIV (F1) (F6) (FP), SHR (FR), LPI (LP), AND WIV (WV) SERIES

Make sure the piping inside diameter is adequate because this type of valve extends into upstream and downstream piping. Additionally, make sure there are no obstructions that would disrupt fluid flow or interfere with poppet travel. Install each valve between ANSI raised face flanges with a gasket on each side of the valve (PTFE valves need no gaskets). Ensure that each valve is centered inside the bolt circle and tighten the bolts. Note: Plastic material valves can be damaged by over-tightening the bolts and by piping systems that add additional loads to valve flanged joints. If a valve flag with a flow arrow is attached to the valve, the tag shall not be rotated or removed so that the flow arrow on the tag remains accurate.

### SANITARY AND GLASS PIPE INSERT VALVES: SIV (CB) (TC), AND GPI (GP) SERIES

Verify that ferrules (CB and TC) or flanges (GP) are correct for each valve to be installed by comparing the fit between the two. If the fit is correct, center the valve in the ferrules or flanges and tighten the clamp or bolts. A valve can be damaged by misalignment, by over tightening, and by piping system loads that affect the joint that contains the valve.

### SANITARY CARTRIDGE VALVES: 3SC (3S) AND SCV (SC) SERIES

The inside diameter of the sanitary tubing must be the size listed in the catalog description of the valve. Lubricate the body o-rings, push the valve into the piping, and then secure the clamp or nut. Note: A valve may leak if piping is misaligned. Also refer to "3S Disassembly For Cleaning Instructions" page 18 and "SC Installation Instructions" (Form #157). See [www.checkall.com](http://www.checkall.com) or request a copy from the factory.

### UNION INSERT VALVES: UIV (UV) SERIES

Note that the union the UV is installed into must have a 45° seat and the ID must be equal to the ID of schedule 40 pipe. Center each valve in the union so the angles match and tighten the union nut enough to seal. Attach the metal identification tag to the union according to its instruction sheet.

### STRAIGHT-SIDED INSERT VALVES: SSI (SI) SERIES

This series is designed to fit in a customer-designed cavity. Note: Forcing a valve into a cavity could cause the seat to deflect or warp and cause leakage.

### UNIVERSAL SOCKET WELD VALVES: UN-SW (US) SERIES

This series is designed to socket-weld into a system. When welding, use standard welding procedures and safety precautions. A material data safety sheet for the body material will be provided upon request. WARNING: A valve can be damaged by excessive heat that may warp or melt the seat and cause it to leak. Use a heat sink or other means to prevent valve damage from occurring.

## MAINTENANCE & INSPECTION:

- Corrosive media. For valves installed in corrosive media, Check-All recommends establishing inspection schedules to ensure the continued safe use of the valve.
- Depressurization & draining. To avoid potential hazards due to discharge, depressurize, and drain the surrounding system prior to removing the valve from the system.
- Surface temperature. To avoid personal injury, do not touch surface of valves if the media within is colder or hotter than room temperature. Allow the valve to return to room temperature prior to removing from the system.
- Valve inspection. For applications that necessitate periodic valve inspection, Check-All can provide, upon request, the critical pressure boundary dimensions of valve bodies. Maintenance or other qualified personnel should also visually inspect the valves for signs of wear that could adversely affect valve performance.
- Cleaning. Care should be exercised when cleaning valves (with steam, chemicals, etc) to protect them against excessive pressure, temperature, and/or corrosion.
- Field repair. Check-All does not recommend field repair for any valve, except the 3S series. If field repair is absolutely necessary contact the factory or the local representative for instructions. A defective valve may be returned to the factory and MUST be accompanied by a completed and signed Return Material Authorization.

## HAZARDS & DAMAGE DUE TO MISUSE:

- Installation next to an "ell". Do not install the valve next to the discharge of an elbow "ell" or directly after any component that could alter or disrupt the flow pattern. Check-All valves are best suited for use with fully developed flow. Although there are many factors affecting the achievement of fully developed flow (such as media, pipe roughness, and velocity), usually (10) pipe diameters of straight pipe immediately upstream of the valve is sufficient. This is particularly important after flow skewing devices such as elbows, tees, centrifugal pumps, etc.
- Shock-load applications. Do not install the valve on the discharge of a reciprocating compressor or any other element that will cause a physical and/or thermal shock-load.
- Pressure limit. Maximum allowed room temperature pressure rating is shown on the pertinent catalog pages, or in the case of valves ordered with CE marks, is on the valve or valve flag supplied. Over-pressurization (due to fluid heating, chemical reaction, explosion, external fire, etc) can cause failure of the valve body and/or the valve internals; therefore, other means must be taken in the surrounding system to prevent this.
- Additional loads & considerations. Pressure ratings are based on internal pressure only. Additional loadings (environmental, head pressure, line-loads, etc) on valves must be accounted for by the end-user. Valve weights are listed in the Check-All catalog or at [www.checkall.com](http://www.checkall.com).
- Temperature limits. Allowable operating temperature limits are shown in the catalog. In the case of valves ordered with CE marks, the limitations are marked on the valve body or accompanying valve flag. Temperatures higher or lower (due to the media, chemical reactions, environmental, conduction, convection, etc) than those allowed can cause failure of the valve body and/or internals. Contact Check-All for temperature range information and reduced pressure ratings at elevated temperatures.
- Corrosive applications. Corrosion allowances are available upon request for all valves. It is the end-user's responsibility to determine the suitability of the valve material for the internal and external environment in which it is used, as well as to establish inspection schedules. Refer to the latest revision of "Body Material Definition for Check-All Valve Products" pages 50 and 51 to determine from what material valve bodies are made. Where the possibility of condensation of gaseous fluids exist, external means in the surrounding system may need to be provided for drainage and removal of deposits from low areas to avoid damage from corrosion. Carbon steel valves are supplied with an oil coating but are not plated.
- Media debris, leakage, & erosion. Check-All valves are best suited for clean, particle-free liquids or gases. Debris such as sand or fibers can prevent the valve from sealing properly, erode the body and/or internal components, or otherwise adversely affect valve travel. These particles should be filtered out prior to entering the valves.
- Valve sizing. Proper operation requires correct valve sizing. If valves are oversized for the operating conditions, trim can chatter and cause excessive wear to the entire valve. Sizing accuracy requires the valve be fully open, which occurs when the pressure drop across the valve reaches or exceeds approximately three times the spring cracking pressure (five times for 3S series). If valve is undersized, pressure drop may be excessive and cause the o-ring to come out of the groove. Valves can be sized using the equations or flow charts located in the Check-All catalog or the Flow Data section of the Check-All website [www.checkall.com](http://www.checkall.com). Contact the factory, [sales@checkall.com](mailto:sales@checkall.com), or your local Check-All representative for further information or assistance.
- Seat leakage. PTFE o-rings, plastic-to-plastic seats, and metal-to-metal seats do not have zero seat-leakage. Allowable leakage rates are listed on page 47 or at [www.checkall.com](http://www.checkall.com) in the Application Guidelines section.
- Decomposition of unstable media. Check-All valves are not designed to withstand excessive temperature and/or pressure beyond their marked limits due to the decomposition of unstable media.
- Fatigue life. CE marked valves have been evaluated using the ASME Boiler and Pressure Vessel Code latest revision or material manufacturer literature. Contact Check-All Valve for minimum number of cycle information. Exceeding the fatigue life of the valve may result in sudden valve failure.
- Safety accessory. Valves are not to be used as safety accessories as defined in the Pressure Equipment Directive (PED) 97/23/EC.
- External fire. Any risk arising from external fire must be accounted for in the surrounding system.
- Galvanic reactions. Suitability of the valve body material when connected with the surrounding piping material is the sole responsibility of the end-user. Galvanic reactions can lead to material loss that can lead to failure of the pressure boundary. Refer to "Body Material Definition for Check-All Valve Products" pages 50 and 51 to determine from what material valve bodies are made.

Check-All Valve Mfg. Co. seeks for the highest level of quality and performance in its products. If you have comments regarding its products, the instructions, require documents referred herein, or need further assistance, please contact your local representative or:

**Check-All Valve Mfg. Co.**  
1800 Fuller Road  
West Des Moines, IA 50265 U.S.A.  
Phone: 515-224-2301 – Fax: 515-224-2326  
Website: [www.checkall.com](http://www.checkall.com) – Email: [sales@checkall.com](mailto:sales@checkall.com)

# Body Material Definition for Check-All Valve Products

To determine the specific material definition, use the following procedure. This grid is the typical designation of body materials. Slight variations may occur due to raw material availability.

- 1) Note the material designation imprinted on the valve body or associated tag. The marking includes the valve style, size, and material. Some examples include:
  - a) FIV: 1-1/2" FIV-15/30-SS this means the size is 1-1/2" NPS, the style is FIV (Flange Insert Valve), it is designed for ANSI class 150 or 300 flanges, or similar and schedule 40 or lighter pipe and the body material code is SS.
  - b) UN-3: UN-3-150-SS this means the style is UN-3, the size is 1-1/2" NPS (150 = 1-1/2", 200 = 2", etc.) and the body material code is SS.
- 2) Now check the material code in the valve marking in the following material definition table to determine the ASTM (American Society of Testing and Materials) material designation. The style size and material code will be needed to define the material. In general, the material codes are as follows:

A2	Alloy 20	HB	HASTELLOY® B Alloy	PV	PVC
BR	Brass or Bronze	HC	HASTELLOY® C Alloy	SS	316 Stainless Steel
CS	Carbon Steel	MO	MONEL® Alloy	TF	PTFE

STYLE	SIZE RANGE	MATERIAL CODE	ASTM MATERIAL (UNS)
3SC (3S)	1" – 4"	SS	ASTM A479 Gr 316/316L (S31600/S31603)
BU (BU)	1/2" x 3/8" to 3" x 2-1/2"	A2 BR CS HB HC MO SS	ASTM B473 (N08020) ASTM B16 H02 TEMPER (C36000) ASTM A108 Gr 1215 (G12150) ASTM B335 (N10665 or N10675) ASTM B574 (N10276) ASTM B164 (N04400 or N04405) ASTM A479 Gr 316/316L (S31600/S31603)
CON (CN)	1/2" – 4"	A2 BR CS HB HC MO SS	ASTM B473 (N08020) ASTM B16 H02 TEMPER (C36000) ASTM A108 Gr 1215 (G12150) ASTM B335 (N10665 or N10675) ASTM B574 (N10276) ASTM B164 (N04400 or N04405) ASTM A479 Gr 316/316L (S31600/S31603)
FIV (F1) (F6)	1/2" – 1-1/4"	A2 BR CS HB HC MO SS	ASTM B473 (N08020) ASTM B16 H02 TEMPER (C36000) ASTM A108 Gr 1215 (G12150) ASTM B335 (N10665 or N10675) ASTM B574 (N10276) ASTM B164 (N04400 or N04405) ASTM A479 Gr 316/316L (S31600/S31603)
FIV (F1)	1-1/2" – 20"	A2 BR CS HB HC MO SS	ASTM A351 Gr. CN7M (N08007) ASTM B062 (C83600) ASTM A216 Gr. WCB (J03002) ASTM A494 Gr. N7M (N30007) ASTM A494 Gr. CW12MW (N30002) ASTM A494 Gr. M-35-2 (N04020) ASTM A351 Gr. CF8M (J92900)
FIV (F6)	1-1/2" – 4"	A2 BR CS HB HC MO SS	ASTM A351 Gr. CN7M (N08007) ASTM B062 (C83600) ASTM A216 Gr. WCB (J03002) ASTM A494 Gr. N7M (N30007) ASTM A494 Gr. CW12MW (N30002) ASTM A494 Gr. M-35-2 (N04020) ASTM A351 Gr. CF8M (J92900)
FIV (FP)	1/2" – 6"	PV TF	ISO 1163-PVC-U, ED, 078-05-33 ASTM D1710 Type 1, Grade 1, Class A or B PTFE
GPI (GP)	1" – 4"	TF	ASTM D1710 Type 1, Grade 1, Class A or B PTFE
HVFD (HV)	1" – 10"	BR CS SS	ASTM B062 (C83600) ASTM A216 Gr. WCB (J03002) ASTM A351 Gr. CF8M (J92900)
HVFD-T (HT)	1" – 2"	CS	ASTM A216 Gr. WCB (Liner = ASTM D1710 Type 1, Grade 1, Class A or B PTFE)

LPI (LP)	1" – 3"	HC TF	ASTM A494 Gr. CW12MW (N30002) ASTM D1710 Type 1, Grade 1, Class A or B PTFE
MCV (M1 - M8)	1/8" – 3/8"	A2 BR CS HB HC MO SS	ASTM B473 (N08020) ASTM B16 H02 TEMPER (C36000) ASTM A108 Gr 1215 (G12150) ASTM B335 (N10665 or N10675) ASTM B574 (N10276) ASTM B164 (N04400 or N04405) ASTM A479 Gr 316/316L (S31600/S31603)
SCV (SC)	3/4" – 4"	SS	ASTM A479 Gr 316/316L (S31600/S31603)
SIV (SV)	3/4" – 4"	TF	ASTM D1710 Type 1, Grade 1, Class A or B PTFE
SSI (SI)	1/2" – 2"	A2 BR CS HB HC MO SS	ASTM B473 (N08020) ASTM B16 H02 TEMPER (C36000) ASTM A108 Gr 1215 (G12150) ASTM B335 (N10665 or N10675) ASTM B574 (N10276) ASTM B164 (N04400 or N04405) ASTM A479 Gr 316/316L (S31600/S31603)
TCV (TC)	1/4" – 2"	BR CS SS	ASTM B16 H02 TEMPER (C36000) ASTM A108 Gr 1215 (G12150) ASTM A479 Gr 316/316L (S31600/S31603)
TCVF (TF)	1/4" – 2"	BR CS SS	ASTM B16 H02 TEMPER (C36000) ASTM A108 Gr 1215 (G12150) ASTM A479 Gr 316/316L (S31600/S31603)
UIV (UV)	1/2" – 2"	A2 BR CS HB HC MO SS	ASTM B473 (N08020) ASTM B16 H02 TEMPER (C36000) ASTM A108 Gr 1215 (G12150) ASTM B335 (N10665 or N10675) ASTM B574 (N10276) ASTM B164 (N04400 or N04405) ASTM A479 Gr 316/316L (S31600/S31603)
UN-10 (U1)	3/8" – 1-1/2"	A2 CS HB HC MO SS	ASTM B473 (N08020) ASTM A108 Gr 1215 (G12150) ASTM B335 (N10665 or N10675) ASTM B574 (N10276) ASTM B164 (N04400 or N04405) ASTM A479 Gr 316/316L (S31600/S31603)
UN-3 (U3)	3/8" – 4"	A2 BR CS HB HC MO SS	ASTM B473 (N08020) ASTM B16 H02 TEMPER (C36000) ASTM A108 Gr 1215 (G12150) ASTM B335 (N10665 or N10675) ASTM B574 (N10276) ASTM B164 (N04400 or N04405) ASTM A479 Gr 316/316L (S31600/S31603)
UN-SW (US)	3/8" – 4"	A2 CS HB HC MO SS	ASTM B473 (N08020) ASTM A108 Gr 1018 (G10180) ASTM B335 (N10665 or N10675) ASTM B574 (N10276) ASTM B164 (N04400 or N04405) ASTM A479 Gr 316/316L (S31600/S31603)
WIV (WV)	1/2" – 4"	A2 BR CS HB HC MO SS	ASTM B473 (N08020) ASTM B16 H02 TEMPER (C36000) ASTM A108 Gr 1215 (G12150) ASTM B335 (N10665 or N10675) ASTM B574 (N10276) ASTM B164 (N04400 or N04405) ASTM A479 Gr 316/316L (S31600/S31603)

Other valve materials are available. If you have a valve made of another material, please consult the factory for the material identification. Please supply the style, size and material code of the valve when contacting the factory.

**Check-All Valve Mfg. Co.** – 1800 Fuller Road – West Des Moines, IA 50265 U.S.A.  
Phone: 515-224-2301 – Fax: 515-224-2326 – Website: [www.checkall.com](http://www.checkall.com) – Email: [sales@checkall.com](mailto:sales@checkall.com)

# Pressure Equipment Directive (PED 97/23/EC) Conformance

All Check-All valves conform to the Pressure Equipment Directive (PED 97/23/EC). In order for pressure equipment products such as check valves to be placed on the open market in the European Community, they must comply with this law, which became mandatory May 29, 2002.

Due to the flexibility of the PED, some valves may require them to be CE marked while the identical valve, in another application, may not require a CE mark. Prior to ordering a PED valve, it must be classified using the PED Annex II Conformity Assessment Tables 6, 7, 8, & 9 (see tables below). Information necessary when using the tables are the valve size, pressure rating, media type (gas or liquid), and the danger presented by the media (dangerous or nondangerous). Note when using the PED tables, Article 3 paragraph 3 of the PED is commonly referred to as Sound Engineering Practice (SEP).

For further information on the PED refer to the European Commission's PED website at [http://europa.eu.int/comm/enterprise/pressure\\_equipment/ped/index\\_en.html](http://europa.eu.int/comm/enterprise/pressure_equipment/ped/index_en.html) or consult the factory for assistance. For assistance with classifying the media as dangerous or nondangerous, refer to European Directive 67/548/EC "Classification, packaging, and labeling of dangerous substances" and any subsequent Directives amending it.

**If the ultimate destination of this product is to the European Economic Union, please indicate this as such at the time of the inquiry so the necessary arrangements can be made.**

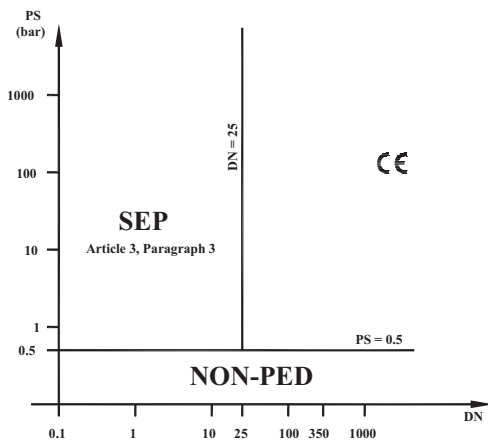

**Table 6**  
Piping Containing a Group 1 (Dangerous) Gas

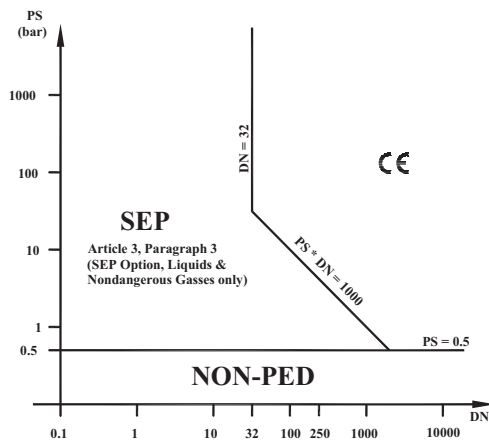

**Table 7**  
Piping Containing a Group 2 (Nondangerous) Gas

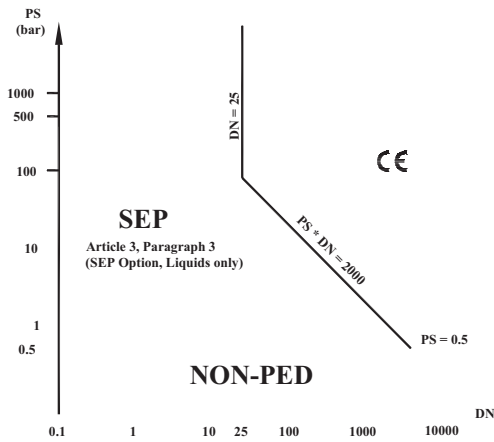

**Table 8**  
Piping Containing a Group 1 (Dangerous) Liquid

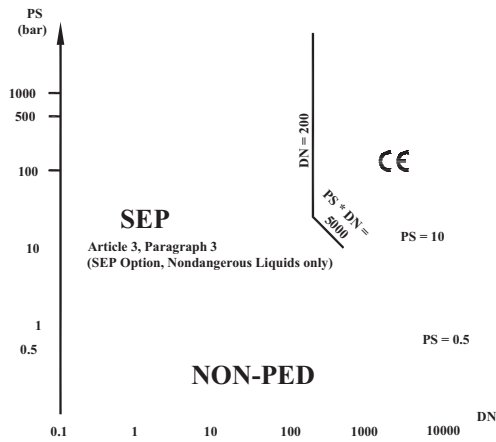

**Table 9**  
Piping Containing a Group 2 (Nondangerous) Liquid

## NON-PED Valves

Some valve styles or valves used at certain operating conditions do not fall under the scope of the PED. These valves are supplied as “NON-PED” valves.

Due to the unique “insert” design of our **SIV (CB, TC)**, **UIV (UV)**, **GPI (GP)**, **SCV (SC)**, & **3SC (3S)** style check valves, they do not constitute an “identifiable pressure bearing housing” as defined in PED Guideline 1/8. These styles must be installed into either ferrules or fittings to create a pressure-bearing housing. Instead, they are classified as “components of pressure equipment” as defined in PED Guideline 1/8.

Applications where the maximum allowed operating pressure is 0.5 bar (7.2 psi) or less also do not fall under the PED, regardless of the valve style.

# Notes

# Copy of Manufacturer's Terms and Conditions of Sale

**1. CONSTRUCTION AND LEGAL EFFECT:** Except as otherwise specifically agreed in writing, our sale to you is limited to and expressly made conditional on your assent to the written terms and conditions of sale on the face and reverse side hereof, all of which form a part of this order and which supersede and reject all prior writings, representations, negotiations with respect hereto and any conflicting terms and conditions of yours, any statement therein to the contrary notwithstanding. The sending of the purchase order for the goods referred to herein, whether or not signed by you, or your acceptance of the goods or payment operates as acceptance by you of our terms and conditions of sale. We will furnish only the quantities and goods specifically listed on the face hereof or the pages attached hereto. We assume no responsibility to terms or conditions or for furnishing other equipment or material shown in any plans and/or specifications for a project to which the goods quoted or ordered herein pertain or refer. Our published or quoted terms and conditions are subject to change without notice.

**2. PRICES:** Unless otherwise noted on the face hereof, prices are net, FOB carrier, our factory. Stenographic, clerical and mathematical errors are subject to correction. Until order is accepted by us, quoted prices are subject to change without notice.

**3. DELIVERY:** Dates for the furnishing of services and/or delivery or shipment of goods are approximate only and are subject to change. Quoted lead times are figured from the date of receipt of complete technical data and approved drawings as such may be necessary. We shall not be liable, directly or indirectly, for any delay in or failure to deliver caused by carriers or delays from labor difficulties, shortages, strikes or stoppages of any sort, failure or delay in obtaining materials from ordinary sources, fires, floods, storms, accidents, causes designated acts of God or force majeure by any statute or court of law or other causes beyond our reasonable control. In no event shall we be liable for any damages or penalties whatsoever, whether direct, indirect, special or consequential, resulting from our failure to perform or delay in performing.

**4. SHORTAGES, DAMAGE, AND ERRORS IN SHIPMENT:** Our responsibility ceases upon delivery to carrier. Risk of loss, injury or destruction of property, shall be borne by you, and such loss, injury or destruction of property shall not release you from payment of purchase price. You shall note receipt for goods that are not in accordance with bill of lading or express receipt without proper notation to the carrier, and you shall make claim against such carrier for any shortage, damage or discrepancy in the shipment promptly. You shall inspect and examine all items and goods covered by the order when unpacking crated or boxed goods, and if damage is discovered, leave as is until the carrier's agent makes examination and notation on freight or express bill of concealed damage. We will render assistance to help trace and recover lost goods and collect just claims as a business courtesy, but without obligation. We do not guarantee safe delivery.

**5. TAXES:** Our prices do not include sales, use, excise, occupation, processing, transportation or other similar taxes which we may be required to pay or collect with respect to any of the materials covered hereby under the existing or future law. Consequently, in addition to the price specified herein, such taxes shall be paid by you, or you shall provide us with a tax exemption certificate acceptable to the appropriate taxing authorities. You shall also assume and pay any import or export duties, with respect to the materials covered by the order, and shall save us harmless therefrom.

**6. CREDIT AND PAYMENT:** Unless otherwise noted on the face hereof, payment of goods shall be (30) days net. Prorate payments shall become due with partial shipments. We reserve the right at any time to suspend credit or to change credit terms provided herein, when, in our sole opinion, your financial condition so warrants. Failure to pay invoices at maturity date, at our election, makes all subsequent invoices immediately due and payable irrespective of terms, and we may withhold all subsequent deliveries until the full account is settled and we shall not, in such event, be liable for non-performance of contract in whole or in part.

**7. DOCUMENTS:** Unless otherwise agreed to in writing, all documents furnished shall be in the English language.

**8. TECHNICAL DOCUMENTS AVAILABILITY:** Check-All Valve Mfg. Co. will supply technical documents to competent governmental authorities upon request as required by law.

**9. CANCELLATIONS AND CHANGES:** Orders which have been accepted by us are not subject to cancellation or changes in specifications; except upon our written consent, and we may require as a condition of such consent, reimbursement for any cost incurred in performance in accordance with the order in original form.

**10. DEFERRED SHIPMENT:** If shipment is deferred at your request, payment of the contract price shall become due when you are notified that the valves are ready for shipment. If you fail to make payment and furnish shipping instructions, we may either extend time for so doing or cancel contract. In case of deferred shipment at your request, storage and other reasonable expenses attributable to such delay shall be payable by you.

**11. WARRANTY:** Check-All Valve Mfg. Co., hereinafter called "Check-All" warrants as follows:

(a) That each new Check-All valve is free from defects in material and workmanship when installed and used in accordance with current Check-All publications.

(b) That each new Check-All valve is fit for the purpose for which similar type valves are ordinarily intended. Purchaser shall be solely responsible for determining suitability for use and in no event shall Check-All be liable in this respect.

**DURATION**—The warranty period shall begin on the date of shipment to the first purchaser and extend for twelve (12) months.

**EXCLUSIVE REMEDY**—Check-All will repair or replace at its discretion, any valve it finds to be defective under this warranty, upon return of the valve, prepaid, to Check-All at 1800 Fuller Road, West Des Moines, IA 50265 or any warehouse designated by Check-All. Except for such repairs or replacements, **CHECK-ALL SHALL NOT BE LIABLE FOR CONSEQUENTIAL DAMAGES RESULTING FROM BREACH OF THIS WRITTEN WARRANTY OR ANY IMPLIED WARRANTY.**

**DISCLAIMER**—Check-All excludes from this warranty compressor discharge applications; valves mounted on the discharge of an elbow ("ell"); and failures due to corrosion, erosion, abrasion, cavitation, or other application-related failures and **DISCLAIMS ANY EXPRESS OR IMPLIED WARRANTY OF FITNESS FOR A PARTICULAR PURPOSE.** Further, it is the end user's responsibility to account for environmental influences such as traffic, wind, earthquake or other external loadings, decomposition of unstable fluids, simultaneous loadings or loadings due to fluid weight. There are no warranties that extend beyond the terms hereof and no one is authorized to assume for Check-All any other liability in connection with the sale of Check-All valves. This warranty supercedes all previous warranties.

**12. LIMITATION OF LIABILITY:** IN NO EVENT SHALL *CHECK-ALL* BE LIABLE FOR ANY DIRECT, INDIRECT, SPECIAL OR CONSEQUENTIAL DAMAGES WHATSOEVER, AND *CHECK-ALL'S* LIABILITY, UNDER NO CIRCUMSTANCES, WILL EXCEED THE CONTRACT PRICE FOR THE GOODS AND/OR SERVICES FOR WHICH LIABILITY IS CLAIMED. ANY ACTION FOR BREACH OF CONTRACT MUST BE COMMENCED WITHIN 1 YEAR AFTER THE CAUSE OF ACTION HAS ACCRUED.

**13. EUROPEAN UNION:** For purposes of defining Check-All Valve products according to the Pressure Equipment Directive, 97/23/EC, these valves are not intended for use as the sole means of isolation.

**14. TEXAS:** Buyers who are business consumers as described in section 17.42 of the Texas Deceptive Trade Practices Act (the "DTPA") waive all provisions of the DTPA to the fullest extent allowed by the DTPA.

**15. APPLICABLE LAW:** The rights and duties of the parties shall be governed by the laws of the State of Iowa.

**16. NO OTHER CONTRACT PROVISIONS:** Except as otherwise previously and specifically agreed in writing by the parties, terms and conditions of your order shall be without force and effect, except as they are identical herewith. No dealer, broker, branch manager, agent, employee or representative of ours has any power or authority except to take orders for our products and to submit the same to us, at our factory, for our approval and acceptance or rejection. There are no representations, agreements, obligations, or conditions, expressed or implied, statutory or otherwise, relating to the subject matter hereof, other than herein contained, and these terms and conditions shall be incorporated in and become a part of any agreement between the parties with reference to purchase of our products.

# WARRANTY

Check-All Valve Mfg. Co., hereinafter called "Check-All" warrants as follows:

- (a) That each new Check-All valve is free from defects in material and workmanship when installed and used in accordance with current Check-All publications.
- (b) That each new Check-All valve is fit for the purpose for which similar type valves are ordinarily intended. Purchaser shall be solely responsible for determining suitability for use and in no event shall Check-All be liable in this respect.

**DURATION**—The warranty period shall begin on the date of shipment to the first purchaser and extend for twelve (12) months.

**EXCLUSIVE REMEDY**—Check-All will repair or replace at its discretion, any valve it finds to be defective under this warranty, upon return of the valve, prepaid, to Check-All at 1800 Fuller Road, West Des Moines, IA 50265 or any warehouse designated by Check-All. Except for such repairs or replacements, CHECK-ALL SHALL NOT BE LIABLE FOR CONSEQUENTIAL DAMAGES RESULTING FROM BREACH OF THIS WRITTEN WARRANTY OR ANY IMPLIED WARRANTY.

**DISCLAIMER**—Check-All excludes from this warranty compressor discharge applications; valves mounted on the discharge of an elbow ("ell"); and failures due to corrosion, erosion, abrasion, cavitation, or other application-related failures and DISCLAIMS ANY EXPRESS OR IMPLIED WARRANTY OF FITNESS FOR A PARTICULAR PURPOSE. Further, it is the end user's responsibility to account for environmental influences such as traffic, wind, earthquake or other external loadings, decomposition of unstable fluids, simultaneous loadings or loadings due to fluid weight. There are no warranties that extend beyond the terms hereof and no one is authorized to assume for Check-All any other liability in connection with the sale of Check-All valves. This warranty supercedes all previous warranties.

## TERMS AND CONDITIONS OF SALE

**Terms:** Net 30 days with approved credit.

**Prices:** FOB FACTORY, West Des Moines, Iowa. All prices subject to change without notice. Any manufacturers' or sales tax or use tax payable on any transaction under any effective statutes will be added to the price of the goods.

**Shipment Data:** All statements of prospective shipping dates are estimates made in good faith. Maximum effort will be made to ship within the time estimated.

**Design:** We reserve the right to make design changes without notice.

**Returns:** All returns must be factory authorized within one year of purchase and are subject to restocking charges. Special valves and valves with permanent tags attached, are not returnable. Contact the factory for a Return Material Authorization form.

**Cancellations:** Firm orders which have been accepted are not subject to cancellation or changes except by written agreement to reimburse the company for costs incurred.

# *Service to Each Customer.*

Since its origin in 1958, Check-All Valve Mfg. Co. has grown from an idea to a reality; from one type of valve to many styles; from a single use to multiple applications; from one material to many. Check-All Valve Mfg. Co. has grown in all respects, yet one element has remained unchanged...service to each and every customer. Please feel free to put our personal and technical services to work on your particular project.

For Additional Details or Specifications contact Check-All Valve Mfg. Co. or your Local Representative.

## **TRADEMARKS USED IN THIS CATALOG:**

HASTELLOY®	.....Haynes International, Inc.
MONEL®	..... Special Metals Family of Companies
INCONEL®	..... Special Metals Family of Companies
VITON®	.....DuPont Performance Elastomers LLC
KALREZ®	.....DuPont Performance Elastomers LLC
TRI-CLAMP®	.....Alfa Laval Inc.
TRI-CLOVER®	.....Alfa Laval Inc.
Q-LINE®	.....SPX Corporation
S-LINE®	.....SPX Corporation
 ®	.....Administered by 3A SSI
AFLAS®	.....Asahi Glass Co., Ltd.

# **2008**

## **INDUSTRIAL AND RESEARCH APPLICATION CATALOG**

ISO 9001-2000 CERTIFIED



**CHECK-ALL VALVE MFG CO.**  
a division of International Valve Corp.  
1800 Fuller Road  
West Des Moines, IA 50265

**PHONE: (515) 224-2301**  
**FAX: (515) 224-2326**  
**www.checkall.com**  
**E-mail: sales@checkall.com**

Publication: CAT-08