

Liquid Ring Compressors - Single and Two Stage

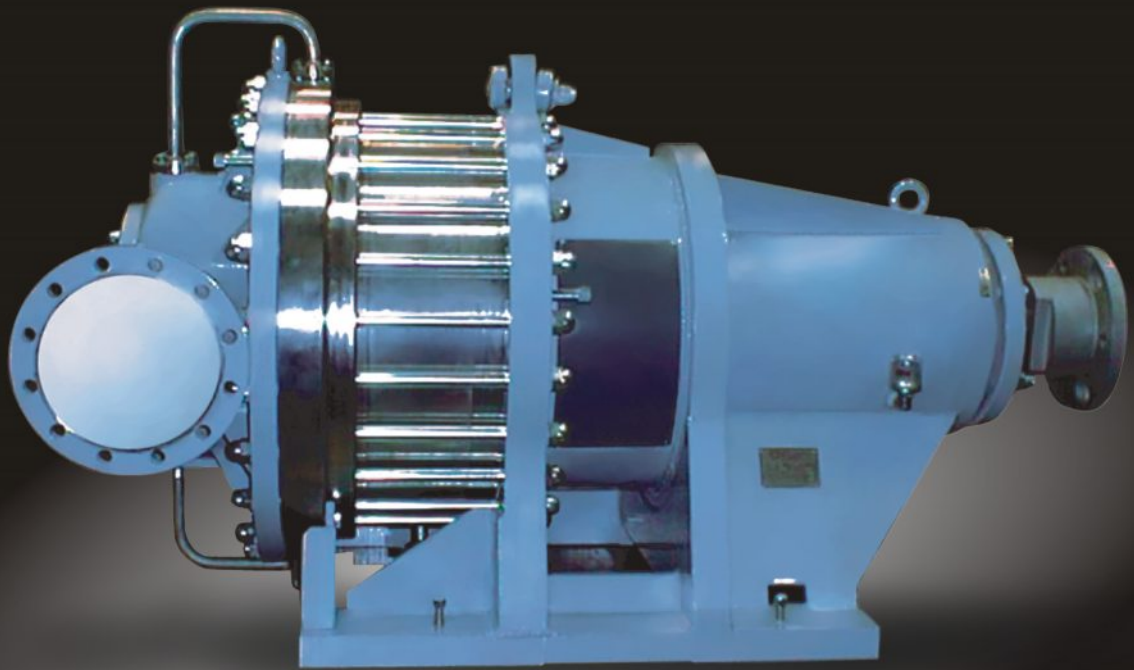



NASH's New Line of Liquid Ring Compressors

NAM & NAB Models

1. Rotor assembly axially removable
2. Oil lubricated ball bearings.
3. Bearing-frame in carbon steel.
4. Easily replaceable casing.
5. Shaft sleeve up to the bearing frame.
6. Shaft in AISI 630. (DIN 1.4542 EN10088)
7. Fully shrouded, one piece, overhung impeller in all units.
8. One shaft sealing area only.
9. Single or double mechanical seal.
10. Four gaskets only.
11. Quick tear-down front cover.

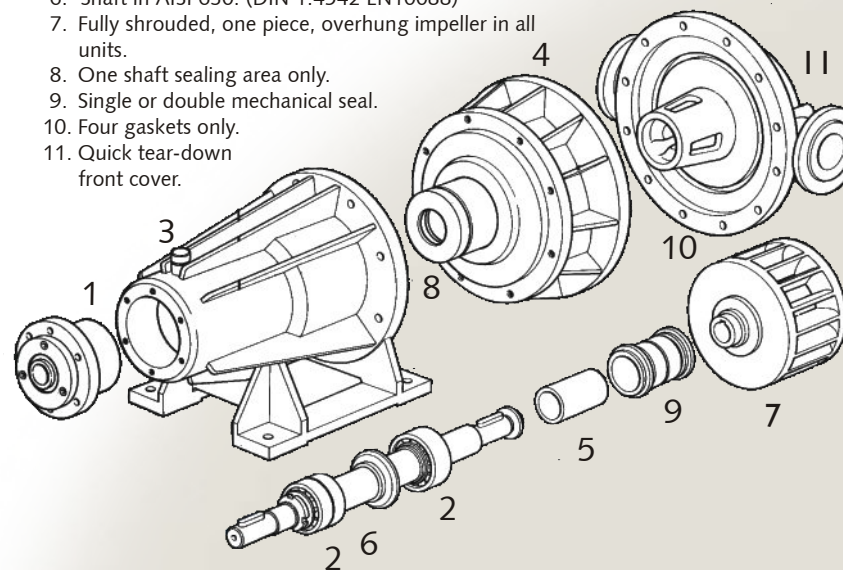

Installation Dimensions

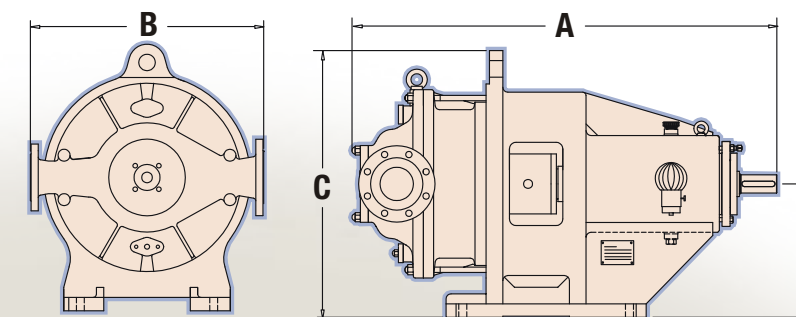

NAM - Single Stage Compressors

Pump Model	A		B		C		D		Inlet Flange		Discharge Flange	
	ANSI (inches)	ISO (mm)	ANSI (inches)	ISO (mm)	ANSI (inches)	ISO (mm)	ANSI (inches)	ISO (mm)	ANSI (inches)	ISO (mm)	ANSI (inches)	ISO (mm)
NAM-400	46.46	1180	27.56	700	31.5	800	15.75	400	4	100	3	80
NAM-600	49	1245	27.56	700	31.5	800	15.75	400	4	100	3	80
NAM-850	50.17	1274	27.56	700	31.5	800	15.75	400	4	100	3	80
NAM-900	57.59	1463	27.17	690	31.5	800	15.75	400	6	150	4	100
NAM-1100	53.25	1353	29.53	750	31.5	800	15.75	400	6	150	4	100
NAM-1500	75	1905	35.43	900	38.58	980	19.69	500	8	200	6	150
NAM-2500	77.94	1980	39.37	1000	42.52	1080	22.05	560	10	250	6	150
NAB-150	39.56	1005	17.72	450	20.27	515	9.84	250	2-1/2	65	1-1/2	40
NAB-250	41.47	1053	24.8	630	28.29	718	14.35	364	3	76	2	51
NAB-600	53.92	1369.6	27.56	700	31.5	800	15.75	400	4	100	3	80
NAB-850	54.59	1387	27.56	700	31.5	800	15.75	400	4	100	3	80
NAB-1100	64.63	1642	35.43	900	34.55	877.5	15.75	400	6	150	4	100
NAB-1500	73.82	1844	39.37	1000	40.16	1020	19.69	500	8	200	6	150
NAB-2500	91.34	2320	39.37	1000	44.1	1120	22.05	560	10	250	6	150
HP-9	62	1575	54	1372	40	1016	20	762	10	254	10	254

The GARO line is Gardner Denver Nash's new line of liquid ring compressor products. It expands the capacity and pressure ranges of our previous compressors to meet the ever-growing requirements of our customers.

Found primarily in petroleum refineries and chemical plants, these rugged and reliable compressors handle highly toxic, explosive and corrosive gases in applications such as flare-gas, chlorine and Vinyl Chlorine Monomer (VCM) recovery. The GARO line, available in single and two-stage designs, comes in: cast iron, stainless steel, carbon steel, spheroidal cast iron, 316 stainless steel, duplex stainless steel, and Hastelloy or Titanium on select models.

Together with the NASH HP-9, the 14 new GARO models form the NASH core compressor product line, which provides compression greater than 200 psig (15 Bar abs). Low pressure compressors are available to 30 psig (3 Bar abs), and 20,000 cfm (34,000 m³/h). As a result, NASH offers the widest pressure and capacity ranges of liquid ring compressors available worldwide.

Gardner Denver Nash carries the GARO line exclusively for the Americas, China, and most of Western Europe excluding Italy, Portugal and Spain, under the agreement with GARO.

Performance

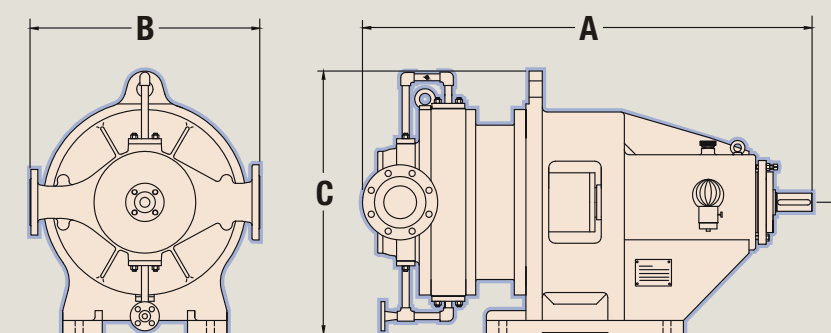
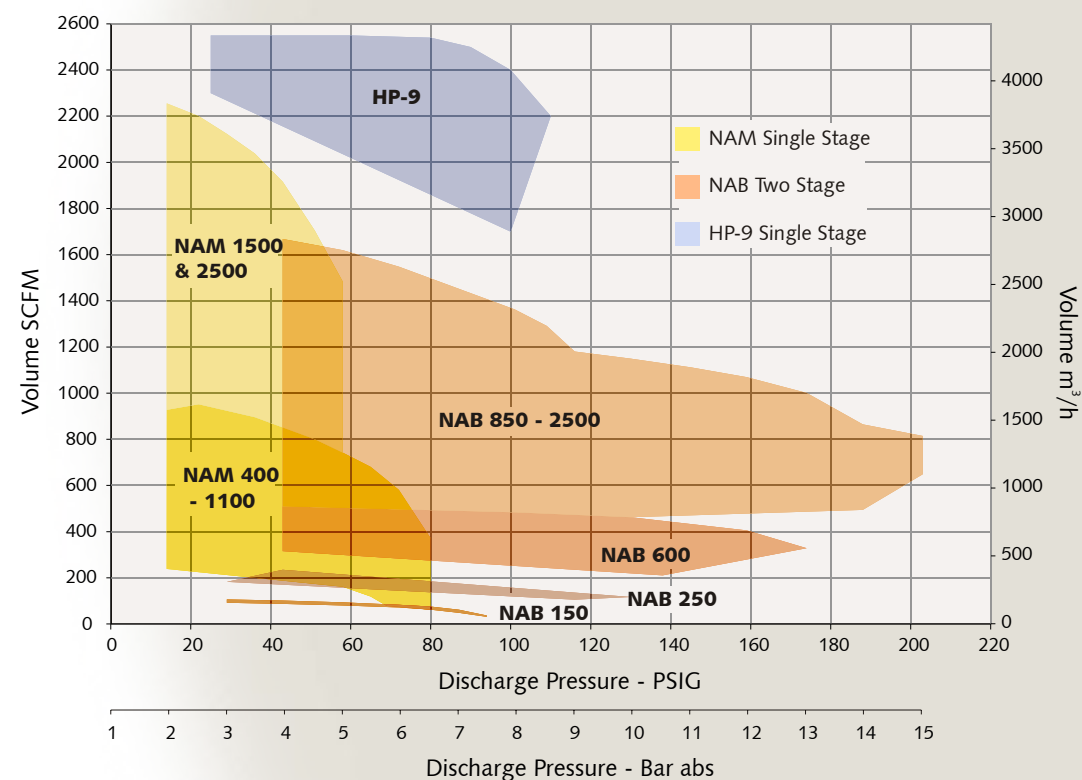

NAB - Two Stage Compressors

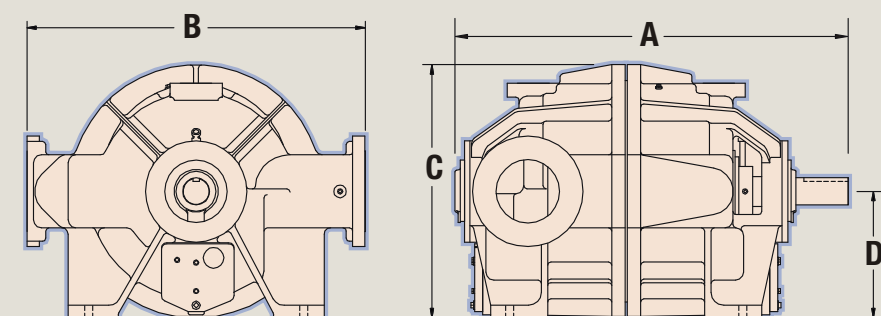

HP-9 - Single Stage Compressor

Other NASH Products

2BV Compact liquid ring vacuum pumps built for serious cost savings
Use up to 50 percent less water than other liquid ring pumps
Monoblock and pedestal designs available
Capacity of 4 to 350 CFM with vacuum to 29+” HgV
Capacity of 7 to 595 m³/h with vacuum to 31 mbar abs.



Vectra Liquid ring vacuum pumps and compressors
Available in feature rich budget designs (XL or GL)
Designed to handle high back pressure requirements
Capacity of 115 to 2,860 CFM with vacuum to 29” HgV
Capacity of 195 to 4,860 m³/h with vacuum to 31 mbar abs.



2BE3/P2620 Large liquid ring vacuum pumps with superior corrosion resistance
Top discharge capability which eliminates need for trench
Self-recirculating seal water, reducing need for external seal water source
Capacity of 4,000 to 23,000 CFM with vacuum to 29+” HgV
Capacity of 6,800 to 39,000 m³/h with vacuum to 31 mbar abs.



TC/TCM Integral two stage liquid ring pumps with improved performance at vacuum levels down to 0.8” HgA (27 mbar)
Designed to handle large amounts of liquid carryover without difficulty
Capacity of 100 to 2,200 CFM with vacuum to 0.8” HgA
Capacity of 170 to 3,740 m³/h with vacuum to 27 mbar



Steam Jet Ejectors Sizes range from one-inch to 78-inch inlets
Capacities range from 20 CFM to 20,000 CFM
Multi-stage system pressures as low as 0.001 mm HgA



NASH

Gardner Denver Liquid Ring Pump Division
9 Trefoil Drive
Trumbull, CT 06611

phone: +1 800 553 NASH

fax: +1 203 459 3988

email: nash@gardnerdenver.com

GardnerDenverNash.com