



www.ktekcorp.com



MT2000 Guided Wave Radar Level and Interface Transmitter

FEATURES

- Standard Single Probe Configurations Eliminate Fowling and Bridging
- Level and Interface Measurement with one Transmitter
- Weak Interface Signal Detector (Patent Pending)
- Widest Selection of Wetted Materials
- Radar Signal Travels Along the Waveguide – Eliminates False Echoes and Minimizes Signal Loss
- No Moving Parts
- 2 Wire Loop Powered
- Linearization Table
- Lengths From 1 to 65 ft. / 0.3 to 19.8 meters
- Local Indication with Scrolling LCD Display
- Rigid, Flexible Cable & Coaxial Probes



OPTIONS

- HART Protocol
- Glass Viewing Window
- 316L Stainless Steel Enclosure

ACCESSORIES

- RI100 Repeater Indicator for Secondary Analog Output
- External Chamber
- Stilling Well

SPECIFICATIONS

Housing	Dual Compartment Powder Coated Aluminum or Stainless Steel
Power	13.5 – 36 VDC, 2 Wire Loop Power
Output	4-20 mA, HART (Secondary Output Available Via HART or RI100)*
LCD Display	Field Selectable Units in Feet, Inches, Millimeters, Centimeters, Meters or Percentage
Accuracy	+/- 0.2 in / 5 mm Upper Level; +/- 1.0 in / 25 mm Interface Level
Resolution	+/- 0.0625 in / 1.6 mm
Range	1 to 65 ft. / 0.3 to 19.8 meters
Process Connection	3/4" NPT Standard
Sensor Material	316L SS Standard, Other Materials Optional
Process Pressure	Up to 5000 psi (344 bar)
Process Temperature	Up to 800°F (427°C)
Process Dielectric Constant	Upper Fluid 1.6 - 5, Lower Fluid 15 - 100+
Process Max Viscosity	1500 cp



Approvals



0539

Factory Mutual Research Corporation

XP / I / 1 / ABCD / T6	Ta = 77C
DIP / II, III / 1 / EFG / T6	Ta = 77C
IS / I / 1 / CD / T4	Ta = 77C - ELE1014
NI / I / 2 / ABCD / T4	Ta = 77C
Type 4X	

CSA Canadian Standards Association

XP	CL I Div 1 GP ABCD
	CL II GP G & Coal Dust
	(Exia) Associated Equip., Provides I.S. Output to Sensor
IS	CL I Div 1 GP CD T4
	CL I Div 2 GP ABCD
	CL II Div 2 GP G & Coal Dust when installed per ELE1014

ATEX

Flameproof: II 1/2 GD EExd IIC T6 (80°C) Tamb +66°C; 02 ATEX 131713
 Intrinsically Safe: II 1 GD EEx ia IIB T6 (80°C) Tamb +66°C; 02 ATEX 131712

The RI100 is not rated intrinsically safe.

ORDERING INFORMATION

MT2000 a/b/c/d/e/f/g/h/i/j/k

/a Select the Probe Material

- S6 316L Stainless Steel Standard
- HC Hastelloy C-276 (Rigid Probes Only)
- HB Hastelloy B3 (Rigid Probes Only)
- MO Monel
- TI Titanium (Rigid Probes Only)

/b Select the Transmitter Configuration

- L Local Transmitter Standard
- LW Local Transmitter with Window Cover Standard

/c Select the Transmitter Housing

- A Dual Compartment Aluminum Housing Standard
- S Dual Compartment 316L Stainless Steel Housing

/d Select the Process Connection / Waveguide Coupler

- Cxo xx Process Connection & Waveguide Coupler (**Table 1**)
- o Seal Code (no code required for /C8) (**Table 2**)

/e Select the Probe Type

- Pxx Probe Code (**Table 3**)

/f Select the Probe Attachment

- CDyyz-w Clamp On Centering Disk (Solid Rod Probes)*
Note: Rigid probes installed in stilling wells or external chambers require centering disk.
- CWyyz-ww Clamp On Centering Weight (Cable Probes)*
Note: Cable probes require a centering weight or end fitting to stabilize bottom of cable.

* A Centering Disk and Weights Guide can be found under the Data Sheet Link in the MT2000 Interface (MT2000I) Product Page in the K-TEK Website (www.ktekcorp.com)

/g Select the Process Temperature Options

- H0 32 to 250°F / 0 to 121°C
- H6 C1 thru C7 and C10 couplers: Above 250°F / 121°C or below 32°F / 0°C
Electronics enclosure is extended 6" above process connection
C8 and C9 couplers: Above 500°F / 260°C
Extends electronics enclosure an additional 6" above process connection
(Refer to **Table 1** for maximum and minimum process temperatures)

/h Select the Electronic Module with 4-20 mA_{dc} Output

- M4A-I LCD Indicator, HART

/i Select the Approvals

- FM Factory Mutual Research Corp. (FM) and Canadian Standards Association (CSA)
- CEI ATEX I.S.
- CEX ATEX Flameproof



/j Select the Process Connection

- P Standard as shown on Probe Process Connection Table
- FL Loose flange or plug for use with probe NPT threads
Specify type, material & rating from Flange Designation Chart (SLG-0001-1)**
- WP Welded process connection
Specify type, material and rating from Flange Designation Chart (SLG-0001-1)* * Welded Flanges size 900# and above may require the use of an H6 extension.

** The Flange Designation Guide can be found under the Data Sheet Link in the MT2000 Interface (MT2000I) Product Page in the K-TEK Website (www.ktekcorp.com)

/k Select the Length

- L Insertion length from face of coupler in inches or millimeters

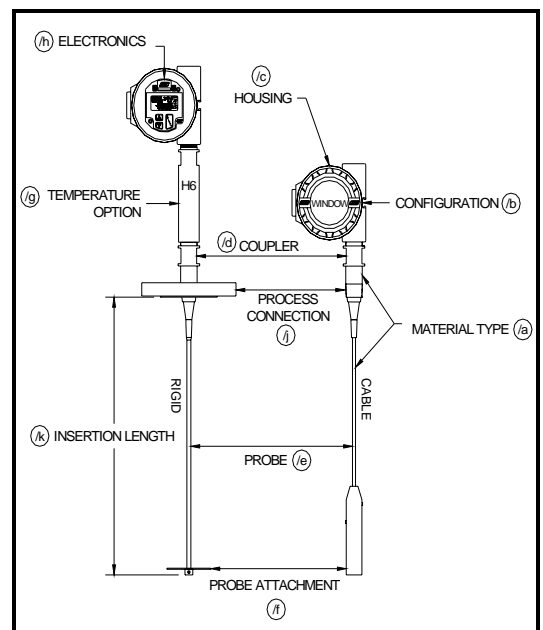

REQUIRED COUPLER / PROBE CONFIGURATIONS

SINGLE PROBE IN STILLING WELL

COUPLER	PROBES
/C1	/P01, /P11
/C2	/P02, /P12
INSERTION LENGTH (IL)	
/P01	1 < IL < 10 FT.
/P02	1 < IL < 20 FT.
/P11, /P12	1 < IL < 30 FT.
MAX. TEMPERATURE	
/C1, /C2	400°F
MAX. PRESSURE @ 100°F	
/C1, /C2	1500 PSI
OPTION TO 3000 PSI	
UNMEASURABLE ZONES	
L1	4 IN.
L2	1 IN. (+ weight height for P11 and P12)

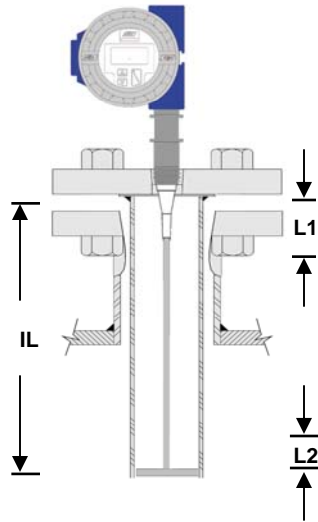

• Preferred Configuration

Note: Stilling Well Size 2" - 4" Pipe; Customer or K-TEK Supplied.

SINGLE PROBE IN EC CHAMBER

COUPLER	PROBES
/C1	/P01, /P11
/C2	/P02, /P12
INSERTION LENGTH (IL)	
/P01	1 < IL < 10 FT.
/P02	1 < IL < 20 FT.
/P11, /P12	1 < IL < 30 FT.
MAX. TEMPERATURE	
/C1, /C2	400°F
MAX. PRESSURE @ 100°F	
/C1, /C2	1500 PSI
OPTION TO 3000 PSI	
UNMEASURABLE ZONES	
L1	4 IN.
L2	1 IN. (+ weight height for P11 and P12)

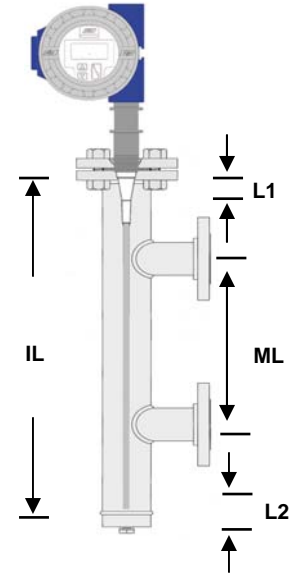

• Preferred Configuration
• Flooded or Non-Flooded

Note: Chamber Size 2" - 4" Pipe; Customer or K-TEK Supplied. Reference EC Data Sheet (EC100-0202-1) to specify / order external chamber available online at www.ktecorp.com on the Displacer Replacer and External Chamber page.

COAX (CLEAN FLUIDS ONLY)

COUPLER	PROBES
/C1	/P51
/C8	/P71
INSERTION LENGTH (IL)	
/P51, /P71	1 < IL < 22 FT.
MAX. TEMPERATURE	
/C1	400°F
/C8	800°F
MAX. PRESSURE @ 100°F	
/C1	1500 PSI
OPTION TO 3000 PSI	
/C8	5000 PSI
UNMEASURABLE ZONES	
L1	4 IN.*
L2	1 IN.

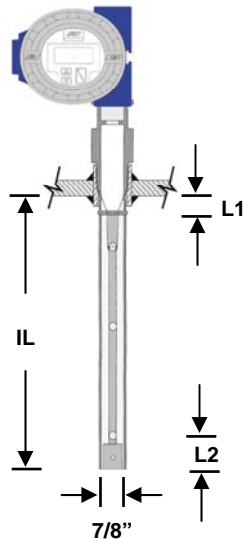

* 0" Available Upon Request.

DUAL PROBE

COUPLER	PROBES
/C4	/P31
/C5	/P22, /P32
INSERTION LENGTH (IL)	
/P22	1 < IL < 30 FT.
/P31, /P32	1 < IL < 65 FT.
MAX. TEMPERATURE	
/C4, /C5	400°F
MAX. PRESSURE @ 100°F	
/C4, /C5	1500 PSI
OPTION TO 3000 PSI	
UNMEASURABLE ZONES	
L1	4 IN.
L2	2 IN. (+ Weight, Height for P31 and P32)

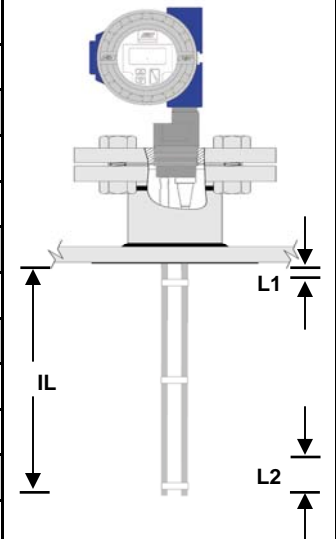

TABLE 1 - PROCESS CONNECTION / WAVEGUIDE COUPLER

Code	Process Connection	Probe Options	Insulator	Seal Options	Temperature Rating	Pressure Rating			
Single Probe			Teflon	Table 2	-60°F - 400°F -50°C - 204°C	1500 psi @ 100°F / 103 bar @ 38°C 600 psi @ 400°F / 41 bar @ 204°C			
/C1	3/4" NPT	/P01, /P11, /P51, /PXX							
/C2	1.5" NPT	/P02, /P12, /PXX							
Dual Probe						Borosilicate Glass	N/A	-60°F - 800°F -50°C - 427°C	With "H" Suffix on Coupler Code
/C4	1.5" NPT	/P31, /PXX							
/C5	2" NPT	/P22, /P32, /PXX							
High Temp / High Pressure			Borosilicate Glass	N/A	-60°F - 800°F -50°C - 427°C	5000 psi @ 100°F / 344 bar @ 38°C 1500 psi @ 800°F / 103 bar @ 427°C			
/C8	1.5" NPT	/P71, /PXX							

MT2000 INTERFACE GUIDELINES

In order to properly detect the level of interface between two liquids using the MT2000, the following rules must be adhered to:

- One of the following probe and mounting configurations must be used:
 - Single rigid rod or flexible cable mounted in a stilling well, external chamber, or existing displacer.*
 - Dual rigid rod or flexible cable
 - Coaxial probe mounted into tank, external chamber, or displacer

* This is the preferred mounting configuration to reduce the chance of fouling.
- Emulsion layers will affect the detection of an interface level. An emulsion layer may negate an interface level indication completely. The MT2000 will read an interface level in the presence of a 2 inch emulsion. The MT2000 is equipped with a weak interface signal detector. This visual indication will let the user know when an emulsion layer may be present.
- The minimum upper fluid thickness must be 4 inches when emulsion is present, and 0 inches with a clean inter face.
- The upper fluid dielectric constant must be greater than 1. 6 and less than 5.
- The interface level indication is a calculated value based partially upon the dielectric of the upper fluid. The upper fluid dielectric must remain constant for consistency / accuracy in the interface level indication.
- The lower fluid dielectric constant must not be less than 15.
- If the application is a flooded condition (sensor completely submerged in process), it must remain completely flooded.
- In a non-flooded condition, the upper fluid must not be allowed to enter the upper unmeasurable zone. The upper unmeasurable zone is typically located within the mounting nozzle of the vessel.

If the required interface application does not fall within the above mentioned parameters, please consult the factory for an alternate technology, such as a Magnetostrictive, Magnetic Level Gauge or RF Capacitance.

TABLE 2 O-RING SEALS

Suffix	Description	Temperature Range
V	Viton	-15°F - 400°F / -26°C - 204°C
K	Kalrez	-40°F - 400°F / -40°C - 204°C
E	EPDM	-60°F - 250°F / -50°C - 125°C

TABLE 3 - PROBE TYPES

Probe Code	O.D.	Description
Single		
/P01	0.25"	Rigid
/P02	0.50"	Rigid
/P11	0.19"	Cable
/P12	0.25"	Cable
Dual		
/P22	0.50"	Rigid
/P31	0.19"	Cable
/P32	0.25"	Cable
Coaxial		
/P51	0.88"	Rigid
/P71	1.32"	Rigid
Custom		
/PXX	Consult Factory	