

continuous
emissions
monitoring



LAND

Combustion & Environmental Monitoring

An **AMETEK**® Company

FGA

Continuous Emissions & Combustion Efficiency Monitoring



The FGA range of analyzers use dual sensor technology to measure the levels of Nitrogen Oxides, Carbon Monoxide and Oxygen in flue gas.

Land's measurement technique ensures stable long-term operation with high accuracy and very low drift. Engineered for ease of maintenance and packaged for the industrial environment, FGA series analyzers are simple to install and trouble-free in operation.

**for stand-alone use or as part of a fully-integrated system
- to meet the demands of modern environmental legislation.**

Features & Benefits

- **Fully integrated system in a single compact box** - *no additional components required*
- **Suitable for a wide range of applications** - *up to 3 gases in a single analyzer*
- **Low maintenance** - *straightforward servicing without specialist skills*
- **Proven high performance** - *dual sensor measurement technique, TÜV & MCerts approved/ Certified to US EPA standards*
- **True measured Total NO_x** - *separate NO + NO₂ sensors for true NO_x monitoring, no converters necessary*
- **Simple installation** - *locate the analyzer anywhere, including outside locations*
- **Automatic calibration option** - *for continuous unattended operation in compliance monitoring applications*
- **Combustion Efficiency measurement option** - *for optimizing process efficiency where conditions are changing*

Compact Weatherproof Design

FGA analyzers are very compact. The choice of installation location and access is therefore made much simpler. They are packaged in weatherproof cabinets, intended for mounting directly on to a convenient wall or structure, inside or outside.

True NO_x Measurement

The analyzer measures both NO and NO₂ separately, these are combined to give a true NO_x measurement output. The inherent problems with catalytic NO₂ converters are therefore completely avoided.



Flexible Configuration

FGA analyzers are available in a range of configurations, as shown in the table.

Automatic Calibration

Each analyzer is fitted with manual calibration as standard. Automatic calibration is optional and enables the analyzer to perform a calibration without operator intervention.

Efficiency

A calculation of overall combustion efficiency can be made for process optimization. It is optional on analyzers fitted with Oxygen sensors.

CO₂

A calculated CO₂ output can be provided on all models that measure O₂.

Model	Gas Type				
	CO	O ₂	NO	NO ₂	NO _x
900	•				
930	•	•			
940		•	•		•
942		•	•	•	•
945			•	•	•
950	•	•	•		•

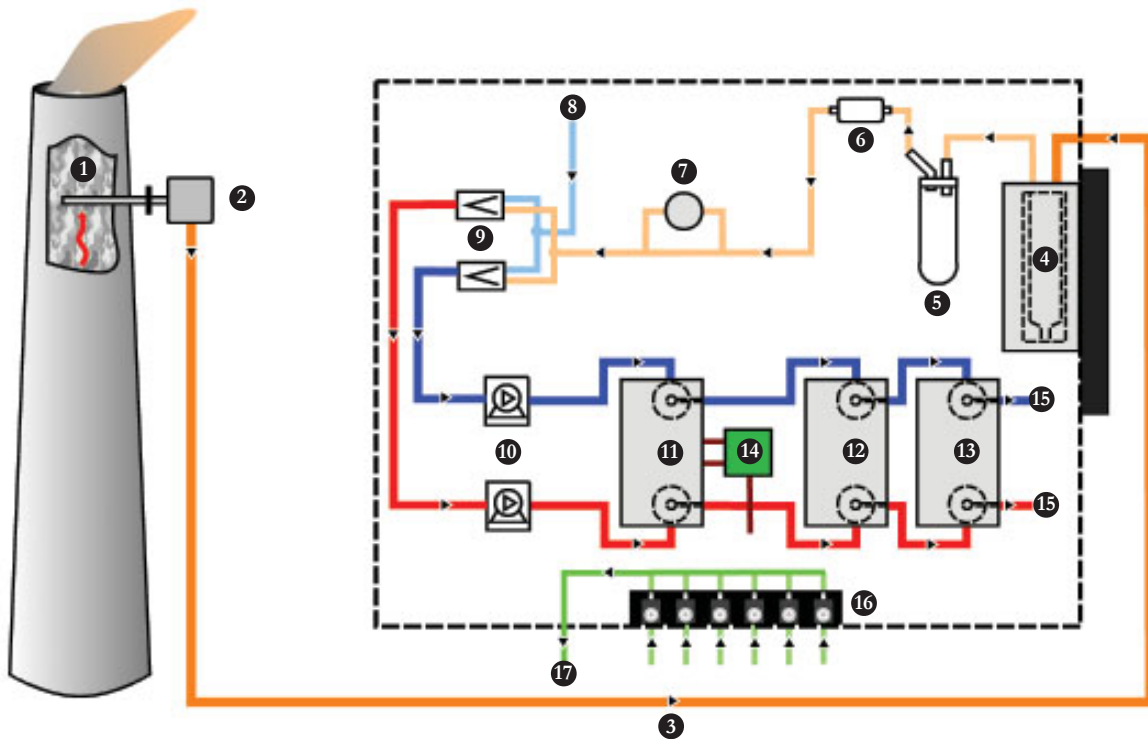

How the Analyzer Works

FGA is an extractive sampling multi-gas analyzer system. The flue gas is extracted using a sample probe. The gas is then transported via a sample line, to the cooler unit fitted inside the analyzer, where the moisture is removed. The dry and cooled sample gas is then filtered to remove particulates before being directed into the measurement system. The measurement system is made up of pairs of sensors. Each sensor is fed alternately with sample gas and air. The sensors generate an electrical output in proportion to a specific gas component. Measured values are then displayed and output as analog signals (4-20 mA).

Key

1. Flue Gas Stream
 2. Sample Probe
 3. Sample Line
 4. Peltier Sample Cooler Unit
 5. Catch Pot
 6. Particulate Filter
 7. Flow Indicator
 8. Air Inlet
 9. Solenoid Valves
 10. Sample Pumps
 11. Gas Sensor Pair #1
 12. Gas Sensor Pair #2
 13. Gas Sensor Pair #3
 14. CO Sensor Purge Unit
 15. Exhaust
 16. Automatic Calibration Gas Module (optional)
 17. Calibration Gas to Sample Probe (with automatic option)
- Hot Sample Gas
 - Cooled/Cleaned Sample Gas
 - Air
 - Measurement Channel #1
 - Measurement Channel #2
 - Calibration Gas

FGA SYSTEMS

CEM Systems - Tailored to your Needs

FGA series analyzers are extremely compact, and are ideal for incorporation into custom-built systems. Land can create solutions which conform with the most exacting specifications. From site-specific installation drawings to complete system engineering packages, Land has the experience to produce designs which perform to the highest standards.

- **Special mounting arrangements**
- **Gas bottle cabinets and regulators**
- **Termination boxes and isolation relays**
- **Multiple probes with manual or automatic selection**
- **Explosion-proof systems**
- **Customer-specific drawings and manuals**



Probes and Sample Lines for all Applications

Our experience will help determine which probe and type of sample line will give the best possible results in your application. A full range of heated and unheated probes, filters and sample lines is available to meet all requirements; and more importantly, to keep operating continuously and very efficiently, with the minimum of maintenance.

- **Heated filter probes**
- **Ceramic probes for hot or acidic conditions**
- **Regulated and self-regulating heated sample lines**
- **Unheated sample lines**

Advanced Capability Systems

The FGA^{II} series of analyzers can measure up to six gases (CO, NO, NO₂, SO₂, O₂ and CO₂) in the same compact format. The ChillerProbe is a stack-mounted sampling system, which uniquely filters and cools the flue gas at the sampling point, before being transported to the FGA^{II} for analysis.

For further information please refer to data sheets for FGA^{II} Analyzer (pds 195) and FGA^{II} ChillerProbe (pds 199).

Data Acquisition and Reporting

Comprehensive data acquisition and analysis systems are available with all FGA analyzers. The PC-based software is a highly flexible and fully configurable data acquisition and reporting system for continuous emissions monitoring systems. This inherent flexibility enables it to meet the requirements of Environmental Regulation Authorities throughout the world.

Key Components of the Analyzer

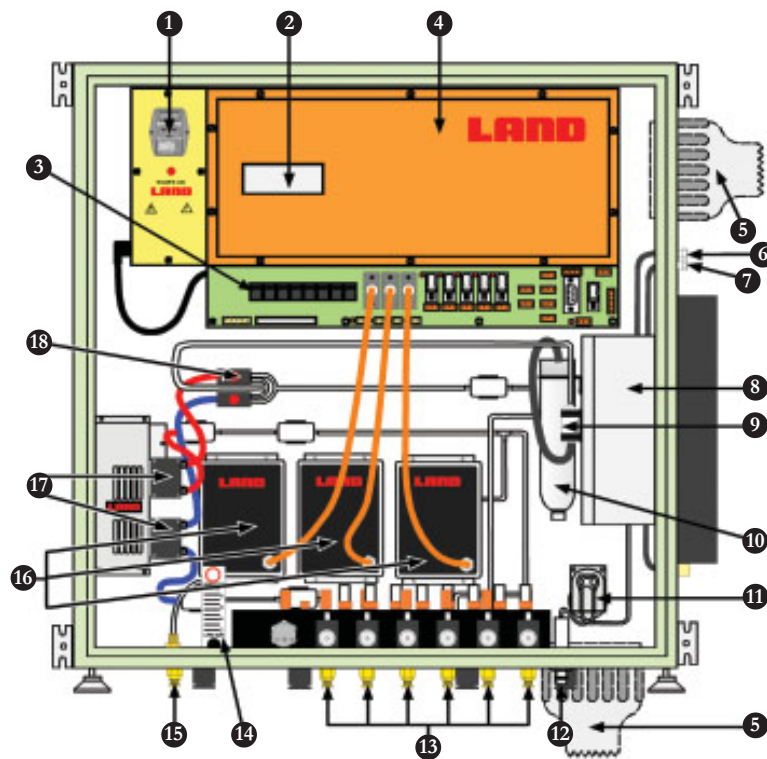

Dual Sensor Technology

FGA analyzers use Dual Sensor Technology to give high measurement accuracy and repeatability. The main advantage of this technology is the automatic zero drift correction the analyzer performs every 30 minutes. In addition, the analyzer performs a measurement verification during the drift correction cycle, ensuring a reliable, repeatable reading.

Continuous emissions monitoring systems using dual sensor technology are in use worldwide and have been certified to US EPA standards PS-3, PS-4 and PS-4A; are MCerts certified; and TÜV approved to the 13th and 17th BImSchV and TA Luft.



Key

1. Power Switch & Fuse
2. LCD Display
3. Menu Operation Keys
4. Electronics Panel
5. Sample Line Connection Boot
(optional heated/ anti-freeze sample line)
6. Compressed Air Inlet
7. Sample Gas Inlet (standard sample line)
8. Peltier Sample Cooler Unit
9. Particulate Filter
10. Catchpot
11. Condensate Peristaltic Pump
12. Condensate Drain
13. Calibration Gases and Air Inlets[#]
14. Calibration Gas Flowmeter and Needle Valve[#]
15. Calibration Gas outlet to probe
16. Sensor Units 1, 2 and 3
17. Sample Pumps
18. Solenoid Valves

[#]Fitted on Automatic Calibration models only

Further Information

UK

Land Instruments International Ltd
Dronfield,
Derbyshire, S18 1DJ
Tel: +44 (0) 1246 417691
Fax: +44 (0) 1246 290274
E-Mail: combustion.info@landinst.com
Web: www.landinst.com

USA

Ametek LAND, Inc.
10 Friends Lane
Newtown, PA 18940-1804
Tel: +1 215 504 8000
Fax: +1 215 504 0879
E-Mail: combsales@landinstruments.net
Web: www.landinstruments.net

Poland

Land Instruments Sp z o.o.
ul. Michalowskiego 5/2
31 - 126 Krakow
Tel: +48 (0) 12 632 82 62
Fax: +48 (0) 12 632 24 74
E-Mail: land@land.com.pl
Web: www.land.com.pl

Italy

Land Instruments SRL
Via dell'Industria, 2
20037 Paderno Dugnano MI
Tel: +39 02 9904 0423, 9108 0020
Fax: +39 02 99 04 0418
E-Mail: comb.info@landinst.it
Web: www.landinst.it

France

Land Instruments Sarl
7 Parc des Fontenelles
78870 Bailly
Tel: +33 (0) 1 30 80 89 20
Fax: +33 (0) 1 30 80 89 21
E-Mail: info-combustion@landinst.fr
Web: www.landinst.fr

Mexico

Land Instruments International
Av. Horacia 1132 Planta Baja "B"
Col. Polanco
11550 MEXICO D.F.
Tel + 52 55 5281 1165
Fax + 52 55 5281 5364
E-Mail: ventas@landinstruments.net

Specifications

Measurement Ranges

CO Ranges: 0 - 50 ppm up to 0 - 2 000 ppm
NO Ranges: 0 - 50 ppm up to 0 - 2 000 ppm
NO_x Ranges: 0 - 50 ppm up to 0 - 200 ppm
Resolution: 1 ppm / 1 mg/m³
Linearity: < 2 % of range
Zero drift: < 2 % of range per month
Span drift: < 2 % of range per month

O₂ Ranges: 0 - 5 % to 0 - 25 %
Resolution: 0.1 Vol %
Linearity: < 0.2 Vol %
Zero drift: < 0.2 Vol % per month
Span drift: < 0.2 Vol % per month

Calibration: Microprocessor controlled
Standard Manual gas selection

Display: LCD with backlight
Indicators: External "Power On" and "System OK" LEDs

Outputs/Inputs

Analog outputs: Isolated current loop outputs
One per gas measured plus NO_x if NO & NO₂ measured
Efficiency (on instruments with selected option)
0, 2 or 4 to 10 or 20mA.
Relay outputs: System OK, Maintenance/Calibration
Relay rating: Isolated changeover S.P. 1 A @ 240 V a.c.
5 A @ 24 V d.c. resistive for
Alarm - one per gas measured
Inputs: Span and Zero Gas Relays for calibration gases
Current loop inputs for ambient & process temperatures
(only needed for efficiency calculation)

Environmental

Environmental rating: IP65 / NEMA 4
Operating (ambient) temperature: 0 to +35 °C / 32 to 95 °F standard
to -20 °C / -4 °F with optional case heater
to +50 °C / 122 °F with optional air conditioner

Compliance

Measurement standards: Meets the requirements of ISO 12039, ISO 10849
& ISO 7935
Approvals: TÜV approved to the 13th & 17th BImSchV and TA Luft
MCerts certified Continuous Emissions Monitoring System
USEPA certified to PS-3, PS-4 and PS-4A
Conforms to EN-61010-2
Electrical safety: Conforms to EN-50 081 & EN-50 082
EMC:

Power

Power supply: 110 V a.c. or 230 V a.c. ±20%, 50 - 60 Hz
Power consumption: 300 W

Gas and Air Requirements

Instrument air (zero calibration): 2 bar / 30 psi clean and dry, 5 l/min / 0.2 cfm
Instrument air (cooling): 2 - 10 bar / 30 - 150 psi clean and dry, 90 l/min / 3 cfm
Calibration gas (recommended): 2 bar / 30 psi, 5 l/min / 0.2 cfm
20 litres / 0.7 cu.ft. per calibration approx.
Calibration gas type: Specific to each gas type and measurement span

Dimensions (H x W x D): 600 x 600 x 350 mm / 24" x 24" x 14"
Weight: 53 kg / 117 lb

Options

Special Measurement Ranges
Automatic Calibration
Efficiency Measurement
Probe Type
Sample Line Type
Case Heater
Air Conditioner/Vortex Cooler

Continuous product development may make it necessary to change these details without notice

LAND

www.landinst.com

An **AMETEK**® Company

LAND has a comprehensive range of Combustion and
Environmental Monitoring Instrumentation.



Approval applies to products designed and
manufactured in the UK



Approval applies in the USA



PDS207/09/06