

---

# Sentry

## Features

# Industrial Gas Detection

---

- **Important factors in determination of hazardous gas detection needs**
  - Identify hazards...
  - Assess risk of hazardous event...
  - Comply with laws, insurance requirements...
  - Consider liability, financial risks...
  - Develop and implement a strategy of comprehensive event response and prudent risk management

# The Solution - Sentry

---

## ■ Sentry Gas Risk Management Systems

- Distributed intelligence for local control and remote monitoring
- Comprehensive event response
- User-defined alarm strategy
- Extensive calibration, diagnostic capabilities
- Documentation of due diligence
- Interface to distributed control systems
- Extensive data on gas exposure

# Sentry

- Detection of Hazardous Gases for Protection of Personnel and Facilities
- Comprehensive Gas Risk Management



# Sentry - Basic Configuration

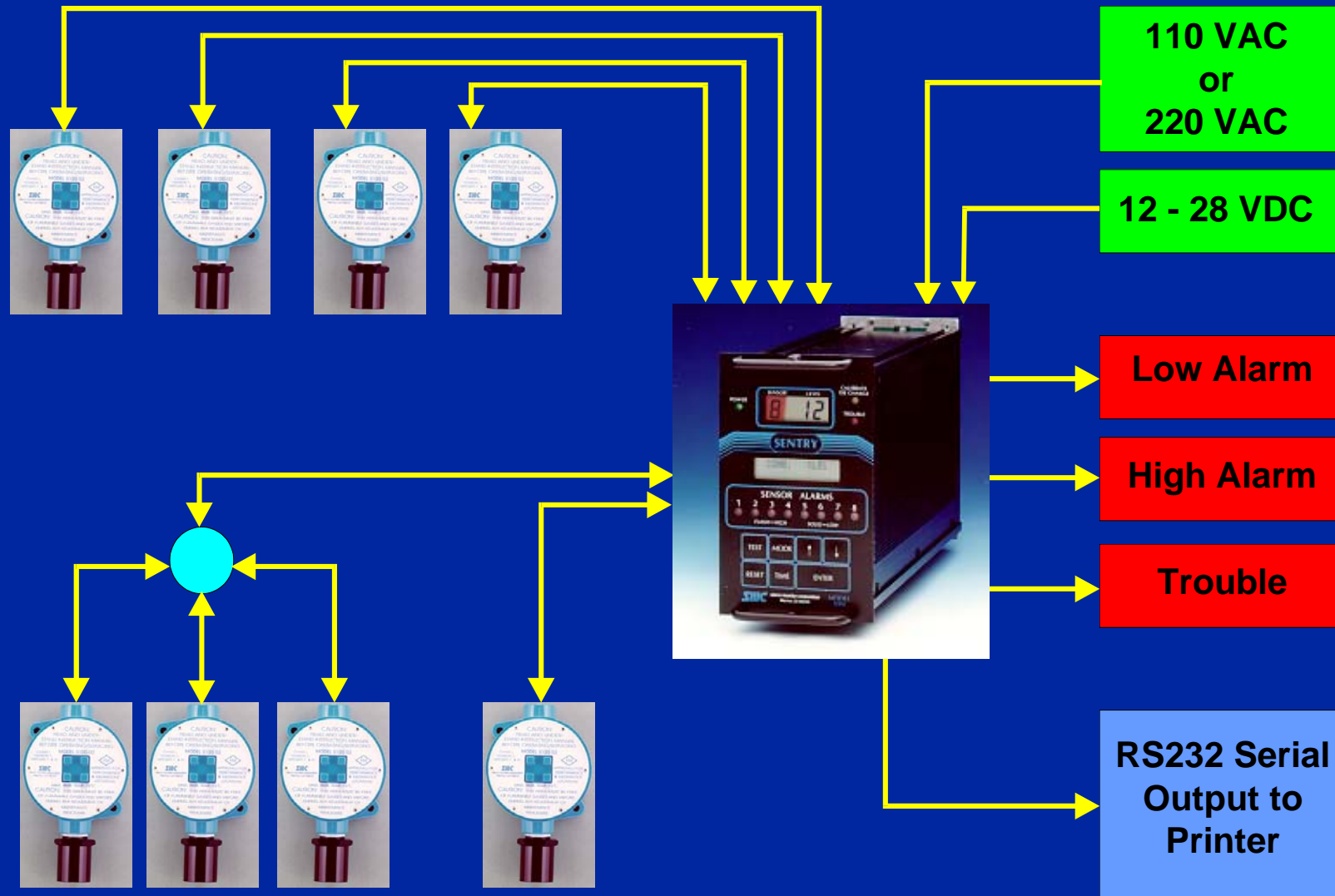

# The Solution - Sentry

---

## Basic Configuration

- Combustibles, Toxic Gases & Oxygen
- 2, 4, or 8 Channels
- Three DPDT Relays
- 110/240 VAC or 12-28 VDC Operation
- Serial Port for Printer
- Battery Back-Up
- Rack, Wall, Panel or NEMA enclosures

## Extended Configuration

- Analog Output
- Individual or Zone Relays
- Single Analog Input
- Multiplexed Analog Input
- Addressable Output Module
- MODBUS
- Remote Power Supply
- Commander
- WebServer

# Sentry - Extended Configuration

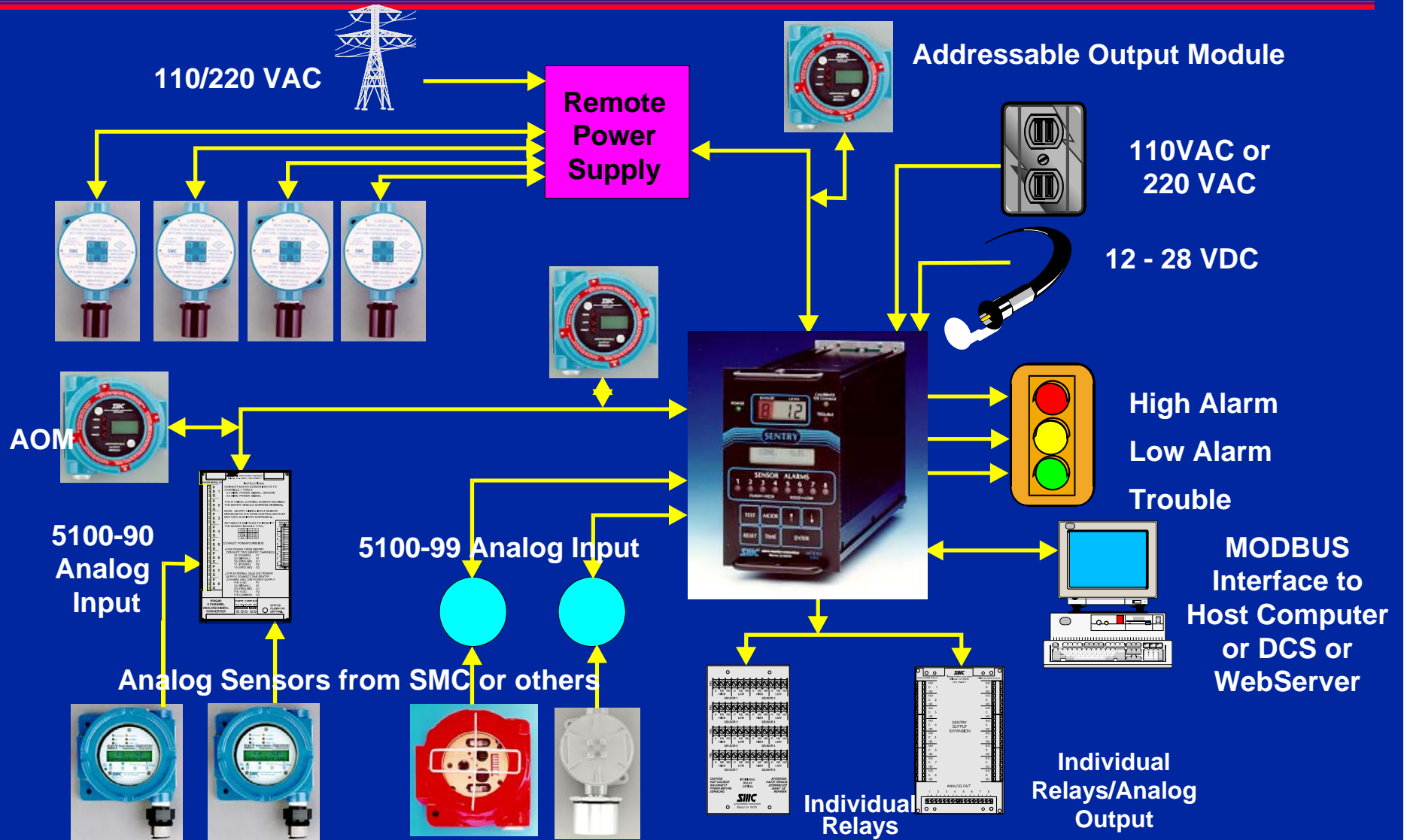

# The Solution - Sentry

---

## ■ The Power of Sentry to Configure to User Needs

- MODBUS, WebServer or printer output for documentation
- Gas or Type tags and Module tags
- Easy to setup alarm, range, calibration, and output configurations
- Accepts wide range of sensors
- Individual relay output, common alarms, analog output, serial output

# Sentry - Data Management Features

---

- **Bi-directional MODBUS communication serial output**
- **Other protocol outputs available including EtherNet/IP, DH+, ControlNet, BACnet, LonWorks, Profibus and more**
- **WebServer for browser-based graphical display**
- **SMC developed graphic screens & configuration**
- **Historical collection of minimum and maximum gas concentration values**
- **Recall and optional printing of system configuration, history, calibration & status**

# User Configurable Features

---

- Gas Tags – identify gas type
- Module Tags – real module name
- Alarm Levels – multiple levels
- Relay Functions
- Calibration Levels
- Input Scaling
- Printer Parameters
- MODBUS and other protocols

# Factory Enhancement Features

---

- Number of Channels
- Printer or MODBUS or WebServer
- Alarm Acknowledge
- Emergency Alarm Value by Gas Tag
- Analog Output
- Non Volatile Gas Tags
- Non Volatile Module Tags

# Reliability

---

- FM Approved for Combustible Gases and Hydrogen Sulfide
- Stable and Repeatable Sensor Modules
- Continuous Internal Self-diagnostics
- Alphanumeric Error Messages
- Fail-safe Trouble Relay
- EMI and RFI Filtering
- Individually Regulated Channel Power Supplies

# User Simplicity

---

- **Single Person Auto-adjusting Non-intrusive Calibration**
- **English language prompts**
- **English language warning messages**
- **English language error messages**
- **Automatic Recognition of New Modules by Address and Type**
- **Browser based graphical display of information**

# Cost Effective

---

- **Easy Non-intrusive Calibration**
- **High Point Count per Instrument Rack**
- **Lower Installation Labor, Wire and Conduit Cost through Multiplexing**
- **Reduced Labor for Set-up, Reports, Calibration and Service**
- **No Periodic Maintenance Except Calibration**

# Versatility

---



- **Battery Back-up**
- **Various Mounting Configurations**
- **Sample Draw Assemblies**
- **Graphical User Interface Programs**
- **Wide Range of Specialized Sensors**
- **Accepts 4-20 mA Input from other Devices**

# Sensors

---



- Combustible Gas
- Hydrogen Sulfide
- Oxygen
- Carbon Monoxide
- Chlorine
- Hydrogen
- Sulfur Dioxide
- Nitrogen Dioxide
- Hydrogen Chloride
- Hydrogen Fluoride
- Hydrogen Cyanide
- Ammonia
- Ethylene Oxide

# Commander

- Central alarming for multiple Sentry Controllers
- Enhanced relay logic and multiple alarm levels
- Connect Sentry System to Ethernet



# Addressable Output Modules

---

- Individual Alarm Relays
- Analog Outputs
- Remote Alarm Reset/Acknowledge
- Distribute Outputs on any channel
- Sentry modules are not “smart” they’re “Brilliant”

# Output Options

---

- Printer output with preformatted reports
- MOBBUS communications output to DCS or other systems or WebServer

# MODBUS - Plant-Wide Monitoring

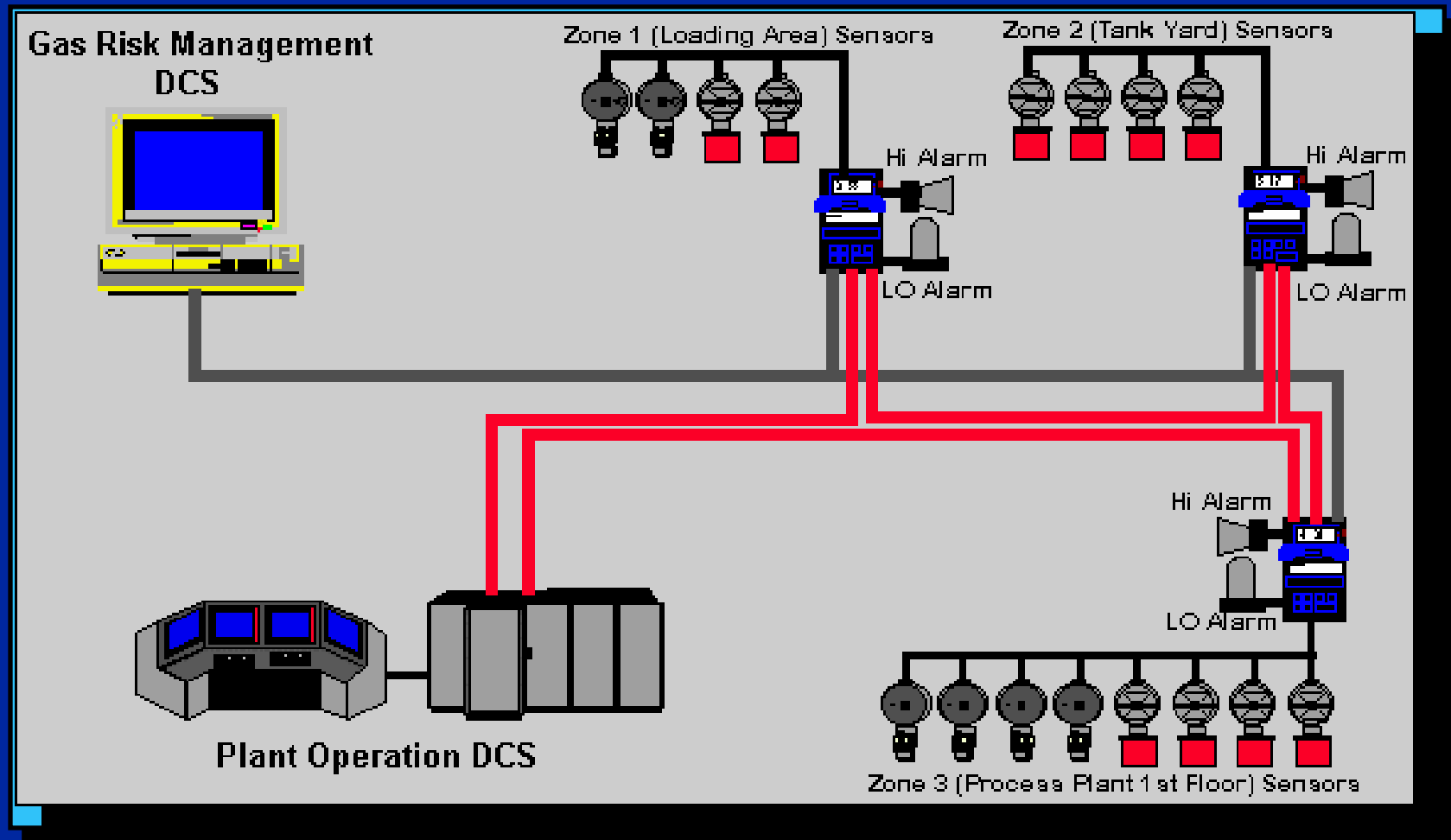

# WebServer

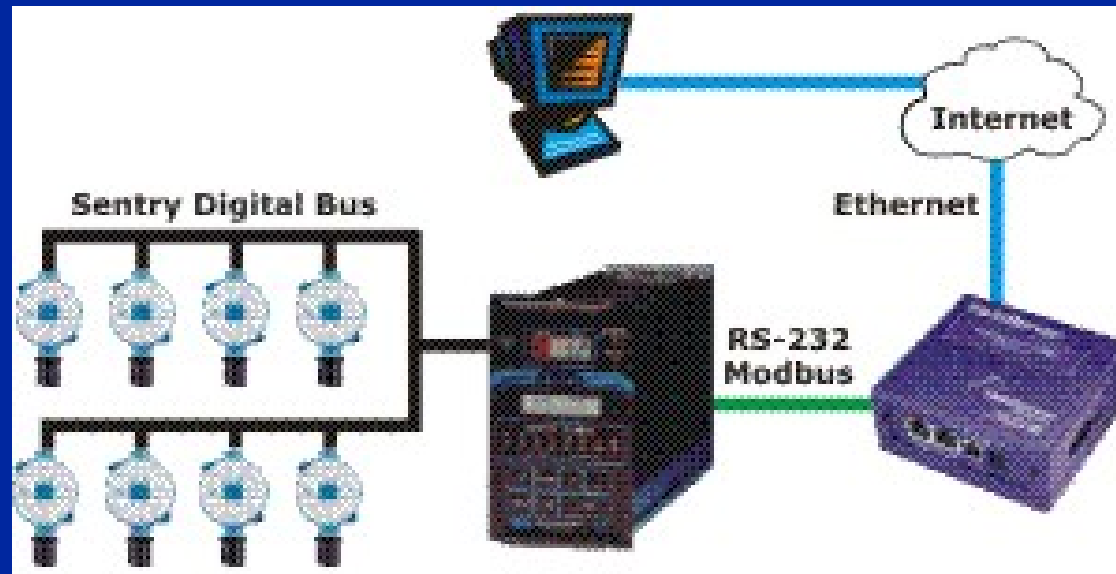

- A WebServer is a cost-effective, easy to configure graphical user interface utilizing a web-browser to display the data
- The WebServer package is provided with a default set of web pages plus developer tools
- Uses ActiveX tools available with the WebServer to enable the user to expand upon provided data screens to develop interactive display screens using Microsoft FrontPage

# Sentry – The Leader

---

- **First** to utilize a microprocessor-based controller for area safety monitoring.
- **First** to use digital two-way communication between the controller and sensor for improved diagnostics, easy one-person calibration and multiplexing configuration.
- **First** to use Modbus serial communication to enable the hazardous gas detection system to link to the plant-wide DCS.
- **First** to include a web browser based WebServer graphical interface in an ambient air monitoring system.

# Sentry – Feature Summary



## Basic Configuration

- Combustibles, Toxic Gases & Oxygen
- 2, 4, or 8 Channels
- Three DPDT Relays
- 110/240 VAC or 12-28 VDC Operation
- Serial Port for Printer
- Battery Back-Up
- Rack, Wall, Panel or NEMA enclosures

## Extended Configuration

- Analog Output
- Individual or Zone Relays
- Single Analog Input
- Multiplexed Analog Input
- Addressable Output Module
- MODBUS
- Remote Power Supply
- Commander
- WebServer